



3000 3200

LP GAS BARBECUE OWNER'S GUIDE

ASSEMBLY - PG. 10



Thank you for purchasing a Weber® barbecue. Now take a few minutes and protect it by registering your product online at www.weber.com®.

YOU MUST READ THIS OWNER'S GUIDE BEFORE OPERATING YOUR GAS GRILL.

⚠ DANGER

If you smell gas:

- 1) Shut off gas to the appliance.
- 2) Extinguish any open flames.
- 3) Open lid.
- 4) If odour continues, keep away from the appliance and immediately call your gas supplier or your fire service.

Leaking gas may cause a fire or explosion which can cause serious bodily injury, death, or damage to property.

⚠ WARNING

- 1) Do not store or use petrol or other flammable liquids or vapours in the vicinity of this or any other appliance.
- 2) A gas supply cylinder not connected for use shall not be stored in the vicinity of this or any other appliance.

⚠ **WARNING:** Carefully follow all leak-check procedures in this Owner's Guide prior to grill operation. Do this even if the grill was dealer-assembled.

⚠ **WARNING:** Do not ignite this appliance without first reading the BURNER IGNITION sections of this Owner's Guide.

OUTDOOR USE ONLY.

NOTICE TO INSTALLER:
These instructions must be left with the owner, who should keep them for future use.

CE:845CO-0017
ID: 0845

57519

EN - INTERNATIONAL ENGLISH
07/31/13

WARNINGS

⚠ DANGER

Failure to follow the DANGERS, WARNINGS and CAUTIONS contained in this Owner's Guide may result in serious bodily injury or death, or may result in a fire or an explosion causing damage to property.

WARNINGS:

- ⚠ Improper assembly of grill may be dangerous. Please follow the assembly instructions carefully.
- ⚠ Do not use this grill unless all parts are in place. The grill must be properly assembled according to the assembly instructions.
- ⚠ Your Weber® gas barbecue should never be used by children. Accessible parts of the barbecue may be very hot. Keep young children, elderly and pets away while barbecue is in use.
- ⚠ Exercise caution when using your Weber® gas grill. It will be hot during cooking or cleaning, and should never be left unattended, or moved while in operation.
- ⚠ Do not use charcoal, briquettes or lava rock in your Weber® gas grill.
- ⚠ While igniting the grill or cooking, never lean over open grill.
- ⚠ Never place hands or fingers on the front edge of the cookbox when the grill is hot or the lid is open.
- ⚠ The entire cookbox gets hot when in use. Do not touch.
- ⚠ Under no circumstances should you attempt to disconnect the gas regulator or any gas fitting while your grill is in operation.
- ⚠ Use heat-resistant barbecue mitts or oven gloves when operating grill.
- ⚠ Follow regulator connection instructions for your type of gas grill.
- ⚠ Should the burners go out while grill is in operation, turn all gas valves off. Open the lid and wait five minutes before attempting to relight grill, using the igniting instructions.
- ⚠ Flammable materials should not be present within approximately 60 cm of the grill. This includes the top, bottom, back or sides of the grill.
- ⚠ Do not build this model of grill in any built-in or slide-in construction. Ignoring this WARNING could cause a fire or an explosion that can damage property and cause serious bodily injury or death.
- ⚠ Do not store an extra (spare) or disconnected gas supply cylinder under or near this grill.
- ⚠ After a period of storage and/or non-use, the Weber® gas grill should be checked for gas leaks and burner obstructions before use. See instructions in this Owner's Guide for correct procedures.
- ⚠ Do not operate your Weber® gas grill if there are any leaking gas connections.
- ⚠ Do not use a flame to check for gas leaks.
- ⚠ Do not put a grill cover or anything flammable on or in the storage area under the grill while grill is in operation or is hot.
- ⚠ Liquid propane gas is not natural gas. The conversion or attempted use of natural gas in a liquid propane gas unit or liquid propane gas in a natural gas unit is dangerous and will void your warranty.
- ⚠ Keep electrical mains lead and the fuel supply hose away from heated surfaces.
- ⚠ Do not enlarge valve orifices or burner ports when cleaning the valves or burners.
- ⚠ The Weber® gas grill should be thoroughly cleaned on a regular basis.
- ⚠ A dented or rusty gas supply cylinder may be hazardous and should be checked by your gas supplier. Do not use a gas supply cylinder with a damaged valve.
- ⚠ Although your gas supply cylinder may appear to be empty, gas may still be present, and the cylinder should be transported and stored accordingly.
- ⚠ Should a grease fire occur, turn off all burners and leave lid closed until fire is out.
- ⚠ Should an uncontrolled flare-up occur, move food away from the flames until flaring subsides.

WARRANTY

Thank you for purchasing a WEBER® product. Weber-Stephen Products LLC (“Weber”) prides itself on delivering a safe, durable and reliable product.

This is Weber’s Limited Warranty provided to you at no extra charge. It contains the information you will need to have your WEBER® product repaired in the unlikely event of a failure or defect.

WEBER’S RESPONSIBILITIES

Weber provides, to the original purchaser of the WEBER® product (or in the case of a gift or promotional situation, the person for whom it was purchased as a gift or promotional item), that the WEBER® product is free from defects in material and workmanship for the period(s) of time specified below when assembled and operated in accordance with the accompanying Owner’s Guide. (Note: If you lose or misplace your WEBER® Owner’s Guide, a replacement is available online at www.weber.com). Under normal, private single family home or apartment use and maintenance, Weber agrees to repair or replace defective parts within the applicable time periods, limitations and exclusions listed below. THIS LIMITED WARRANTY IS EXTENDED ONLY TO THE ORIGINAL PURCHASER AND IS NOT TRANSFERABLE TO SUBSEQUENT OWNERS, EXCEPT IN THE CASE OF GIFTS AND PROMOTIONAL ITEMS AS NOTED ABOVE.

OWNER’S RESPONSIBILITIES

To ensure trouble-free warranty coverage, it is important that you register your WEBER® product online at www.weber.com or via Weber Customer Service at 1-800-446-1071. Please also retain your original sales receipt and/or invoice. Registering your WEBER® product confirms your warranty coverage and provides a direct link between you and Weber in case we need to contact you.

The Owner must take reasonable care of the WEBER® product and follow all assembly instructions, usage instructions and preventative maintenance as outlined in the accompanying Owner’s Guide. If you live in a coastal area, or have your product located near a pool, maintenance includes regular washing and rinsing of the exterior surfaces as outlined in the accompanying Owner’s Guide. If you believe that you have a part that is covered by this Limited Warranty, please contact Weber Customer Service at 1-800-446-1071 or support@weberstephen.com. Weber will, upon investigation, repair or replace (at its option) a defective part covered by this Limited Warranty. In the event that repair or replacement are not possible, Weber may choose (at its option) to replace the barbecue in question with a new barbecue of equal or greater value. Weber may ask you to return parts for inspection, shipping charges to be pre-paid.

This LIMITED WARRANTY does not cover damage, deterioration, discoloration and/or rust caused by:

- Abuse, misuse, alteration, modification, misapplication, vandalism, neglect, improper assembly or installation, and failure to properly perform normal and routine maintenance;
- Insects (such as spiders) and rodents (such as squirrels), including but not limited to damage to burner tubes and/or gas hoses;
- Exposure to salt air and/or chlorine sources such as swimming pools and hot tubs/spas;
- Severe weather conditions such as hail, hurricanes, earthquakes, tsunamis or surges, tornadoes or severe storms.

The use and/or installation of parts on your WEBER® product that are not genuine Weber parts will void this Limited Warranty, and any damages that result are not covered by this Limited Warranty. Any conversion of a gas barbecue not authorised by Weber and performed by a Weber authorised service technician will void this Limited Warranty.

The barbecues illustrated in this Owner’s Guide may vary slightly from the model purchased.

PRODUCT WARRANTY PERIODS

Cookbox: 5 years, no rust through/burn through
(2 years paint excluding fading or discoloration)

Lid assembly: 5 years, no rust through/burn through
(2 years paint excluding fading or discoloration)

Stainless steel burner tubes: 5 years, no rust through/burn through

Porcelain-enamelled
cast iron cooking grates: 5 years, no rust through/burn through

Plastic components: 5 years, excluding fading or discoloration

All remaining parts: 2 years

DISCLAIMERS

WEBER MAKES NO IMPLIED WARRANTIES INCLUDING WITHOUT LIMITATION ANY IMPLIED WARRANTY OF MERCHANTABILITY OR FITNESS FOR A PARTICULAR PURPOSE, OTHER THAN WHAT IS EXPRESSLY MADE IN THIS LIMITED WARRANTY. NO WARRANTIES SHALL APPLY AFTER THE APPLICABLE PERIODS OF THIS LIMITED WARRANTY. NO OTHER WARRANTIES GIVEN BY ANY PERSON OR ENTITY, INCLUDING A DEALER OR RETAILER WITH RESPECT TO ANY PRODUCT (SUCH AS ANY “EXTENDED WARRANTIES”), SHALL BIND WEBER. THE EXCLUSIVE REMEDY OF THIS LIMITED WARRANTY IS REPAIR OR REPLACEMENT OF THE PART OR PRODUCT. THE TERMS OF THIS LIMITED WARRANTY PROVIDE THE SOLE AND EXCLUSIVE REMEDY ARISING FROM THE SALE OF THE PRODUCTS COVERED HEREBY. WEBER SHALL NOT BE LIABLE FOR ANY SPECIAL, INDIRECT, INCIDENTAL OR CONSEQUENTIAL LOSS OR DAMAGES. SOME JURISDICTIONS DO NOT ALLOW THE EXCLUSION OR LIMITATION OF INCIDENTAL OR CONSEQUENTIAL DAMAGES, OR LIMITATIONS ON HOW LONG AN IMPLIED WARRANTY LASTS, SO THE ABOVE EXCLUSIONS OR LIMITATIONS MAY NOT APPLY TO YOU.

IN NO EVENT SHALL RECOVERY OF ANY KIND BE GREATER THAN THE AMOUNT OF THE PURCHASE PRICE OF THE WEBER PRODUCT SOLD.

YOU ASSUME THE RISK AND LIABILITY FOR LOSS, DAMAGE, OR INJURY TO YOU AND YOUR PROPERTY AND/OR TO OTHERS AND THEIR PROPERTY ARISING OUT OF THE MISUSE OR ABUSE OF THE PRODUCT OR FAILURE TO FOLLOW INSTRUCTIONS PROVIDED BY WEBER IN THE ACCOMPANYING OWNER’S GUIDE.

THIS LIMITED WARRANTY GIVES YOU SPECIFIC LEGAL RIGHTS, AND YOU MAY ALSO HAVE OTHER RIGHTS THAT VARY IN DIFFERENT JURISDICTIONS.

PARTS AND ACCESSORIES REPLACED UNDER THIS LIMITED WARRANTY ARE WARRANTED ONLY FOR THE BALANCE OF THE ORIGINAL WARRANTY PERIOD(S).

THIS LIMITED WARRANTY APPLIES TO PRIVATE SINGLE FAMILY HOME OR APARTMENT USE ONLY AND DOES NOT APPLY TO WEBER BARBECUES USED IN COMMERCIAL, COMMUNAL OR MULTI-UNIT SETTINGS SUCH AS RESTAURANTS, HOTELS, RESORTS OR RENTAL PROPERTIES.

WEBER MAY FROM TIME TO TIME CHANGE THE DESIGN OF ITS PRODUCTS. NOTHING CONTAINED IN THIS LIMITED WARRANTY SHALL BE CONSTRUED AS OBLIGATING WEBER TO INCORPORATE SUCH DESIGN CHANGES INTO PREVIOUSLY MANUFACTURED PRODUCTS, NOR SHALL SUCH CHANGES BE CONSTRUED AS AN ADMISION THAT PREVIOUS DESIGNS WERE DEFECTIVE.

TABLE OF CONTENTS

WARNINGS	2
WARRANTY	3
TABLE OF CONTENTS	3
WEBER® Q® 3000 EXPLODED VIEW	4
WEBER® Q® 3200 EXPLODED VIEW	6
PARTS LIST	8
ASSEMBLY	10
STORAGE FEATURES	23
IMPORTANT INFORMATION ABOUT LP GAS & GAS CONNECTIONS	24
WHAT IS LP GAS?	24
SAFE HANDLING TIPS FOR LPG CYLINDERS	24
STORAGE AND NON-USE GUIDELINES	24
LPG CYLINDER REQUIREMENTS	24
REGULATOR CONNECTIONS & REQUIREMENTS	24
LPG CYLINDER INSTALLATION	25
WHERE DOES THE LPG CYLINDER GO?	25
REQUIREMENTS FOR INSTALLATION ON CART	25
INSTALLATION ON CART	26
REQUIREMENTS FOR INSTALLATION ON GROUND	26
INSTALLATION ON GROUND	26
CONNECTING THE REGULATOR	27
WHAT IS A REGULATOR?	27
CONNECTING THE REGULATOR TO THE LPG CYLINDER	27
PREPARING TO USE YOUR BARBECUE	28
WHAT IS A LEAK CHECK?	28
CHECKING FOR GAS LEAKS	28
DISCONNECTING THE REGULATOR	30
DISCONNECTING THE REGULATOR FROM THE LPG CYLINDER	30
REFILLING THE LPG CYLINDER	30
RECONNECTING THE LPG CYLINDER	30
SAFETY CHECKS BEFORE USING YOUR BARBECUE	31
SAFETY FIRST	31
REMOVABLE CATCH PAN AND DISPOSABLE DRIP PAN	31
HOSE INSPECTION	31
BURNER IGNITION & USAGE	32
METHODS OF BURNER IGNITION	32
BURNER IGNITION	32
TO EXTINGUISH BURNER	32
BARBECUING TIPS & HELPFUL HINTS	34
TIPS & HINTS	34
PREHEATING	34
COVERED COOKING	34
GREASE COLLECTION SYSTEM	34
COOKING METHODS	36
DIRECT METHOD OR INDIRECT METHOD?	36
TROUBLESHOOTING	37
GENERAL TROUBLESHOOTING	37
GRILL OUT® HANDLE LIGHT TROUBLESHOOTING	37
ANNUAL MAINTENANCE	38
KEEPING YOUR WEBER® GAS BARBECUE IN TIP-TOP SHAPE	38
BURNER FLAME PATTERN	38
WEBER® SPIDER/INSECT SCREEN(S)	38
BURNER TUBE PORTS	38
BURNER TUBE CLEANING OR REPLACEMENT	39
ROUTINE MAINTENANCE	41
BEAUTIFUL—INSIDE AND OUT	41
CLEANING THE OUTSIDE OF THE BARBECUE	41
CLEANING THE INSIDE OF THE BARBECUE	41
HOSE INSPECTION	41
IGNITION SYSTEM OPERATIONS	42
MAINTAINING THE PUSH BUTTON IGNITION SYSTEM (Q® 3000)	42
MAINTAINING THE ELECTRONIC IGNITION SYSTEM (Q® 3200)	42
MAINTAINING THE GRILL OUT® HANDLE LIGHT (Q® 3200)	42

WEBER® Q® 3000 EXPLODED VIEW

Q3000_EURO_LP_073113

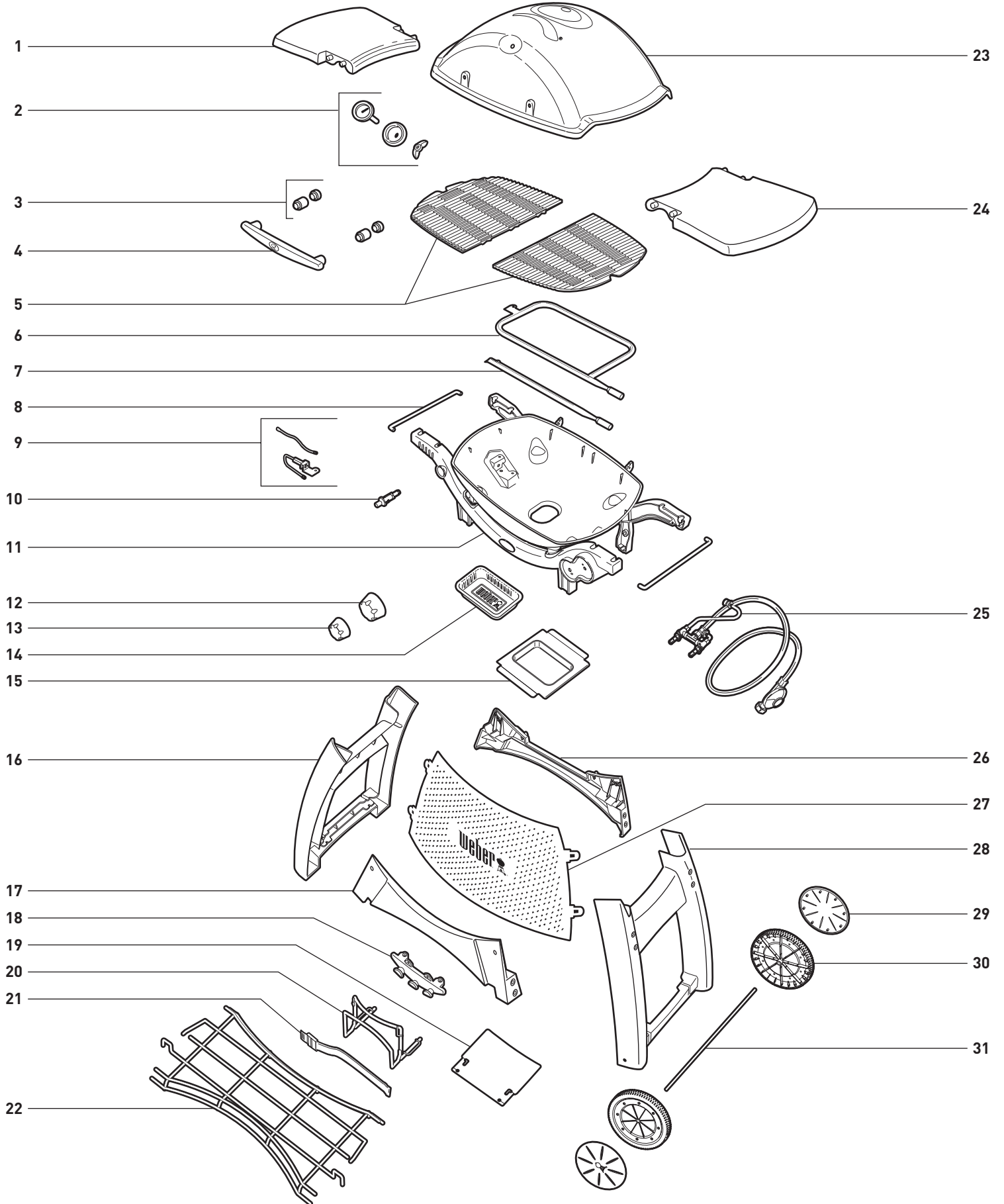

WEBER® Q® 3000 EXPLODED VIEW

1. Left Fold-Down Table
2. Thermometer Assembly
3. Handle Spacer
4. Handle
5. Cooking Grate
6. Outside Burner Tube
7. Inside Burner Tube
8. Wire Brace
9. Igniter Electrode Assembly
10. Push Button Igniter
11. Cookbox/Cradle Assembly
12. Large Burner Control Knob
13. Small Burner Control Knob
14. Disposable Drip Pan
15. Removable Catch Pan
16. Left Cart Leg
17. Front Cross Brace
18. Tool Holder
19. Cylinder Rest
20. Cylinder Bracket
21. Cylinder Strap
22. Bottom Rack
23. Lid
24. Right Fold-Down Table
25. Manifold, Valve and Regulator Assembly
26. Rear Cross Brace
27. Cylinder Screen
28. Right Cart Leg
29. Wheel Cover
30. Wheel
31. Axle

WEBER® Q® 3200 EXPLODED VIEW



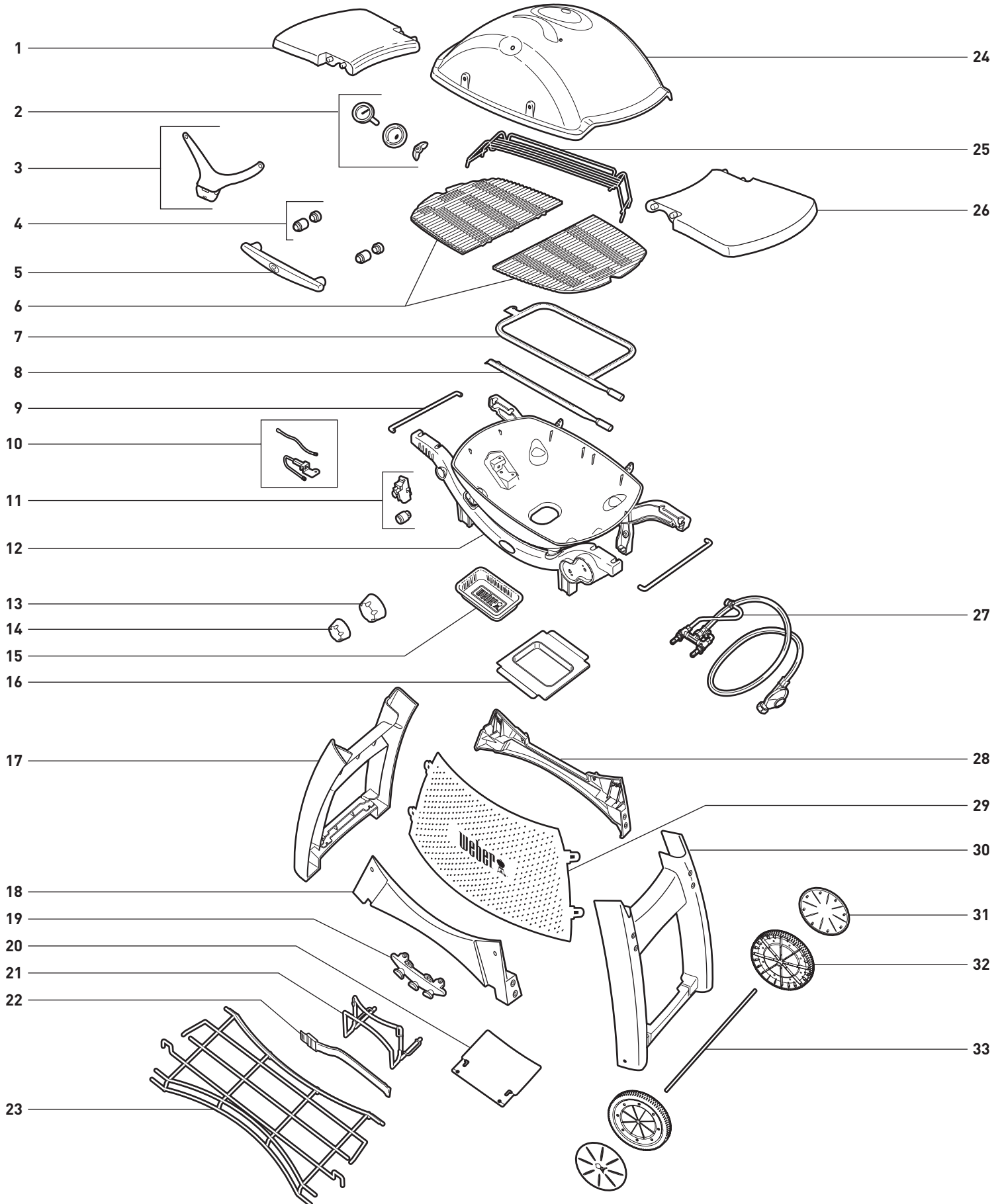







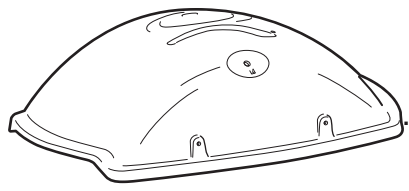

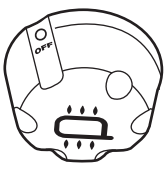
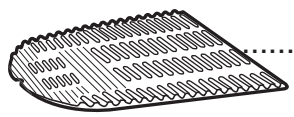
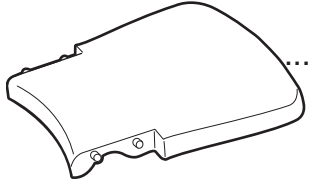
Q3200_EURO_LP_073113

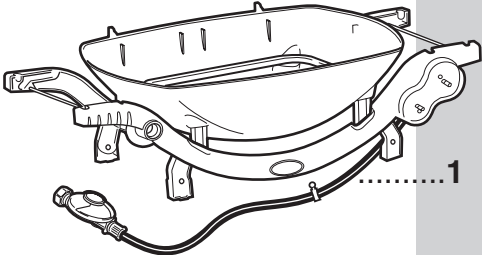

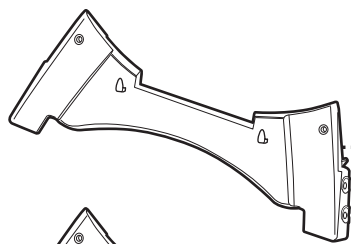
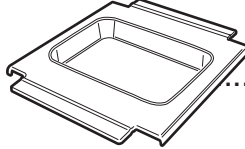
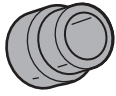
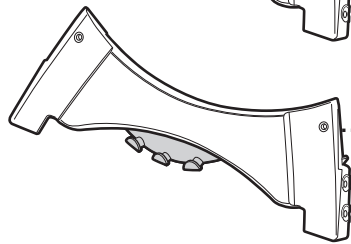
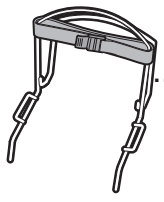
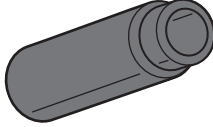
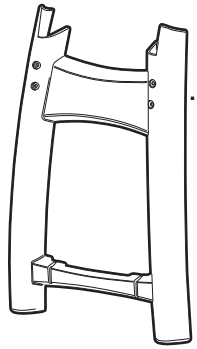
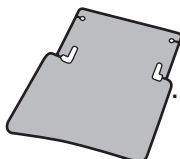
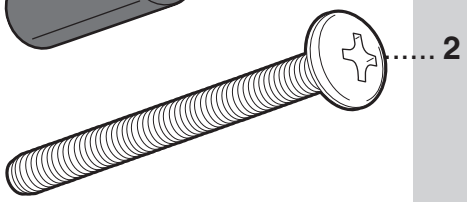
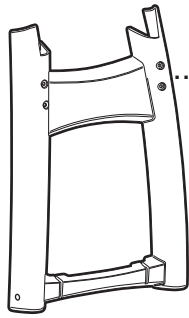
WEBER® Q® 3200 EXPLODED VIEW

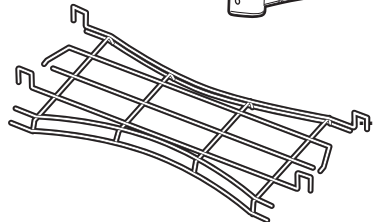
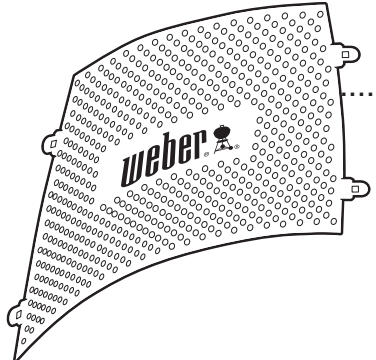
1. Left Fold-Down Table
2. Thermometer Assembly
3. Grill Out® Handle Light Assembly
4. Handle Spacer
5. Handle
6. Cooking Grate
7. Outside Burner Tube
8. Inside Burner Tube
9. Wire Brace
10. Igniter Electrode Assembly
11. Electronic Igniter Button/
Electronic Igniter Module
12. Cookbox/Cradle Assembly
13. Large Burner Control Knob
14. Small Burner Control Knob
15. Disposable Drip Pan
16. Removable Catch Pan
17. Left Cart Leg
18. Front Cross Brace
19. Tool Holder
20. Cylinder Rest
21. Cylinder Bracket
22. Cylinder Strap
23. Bottom Rack
24. Lid
25. Warming Rack
26. Right Fold-Down Table
27. Manifold, Valve and Regulator Assembly
28. Rear Cross Brace
29. Cylinder Screen
30. Right Cart Leg
31. Wheel Cover
32. Wheel
33. Axle

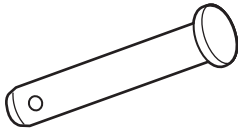
PARTS LIST

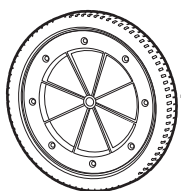
	1		1		1		1
	2		2		1		
	1		1		1		
	1		1		2		
	1		1		2		
	1		1		2		
	1		1		12		
	1		1		4		
					2		
					1		
					2		
					2		

PARTS LIST

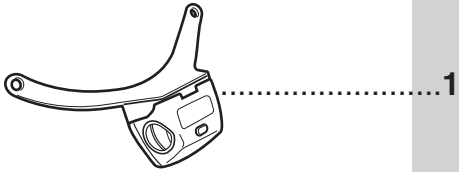
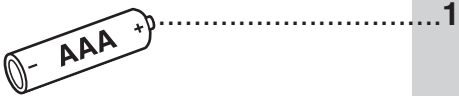
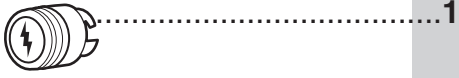

ASSEMBLY

TOOLS NEEDED:



1

2-

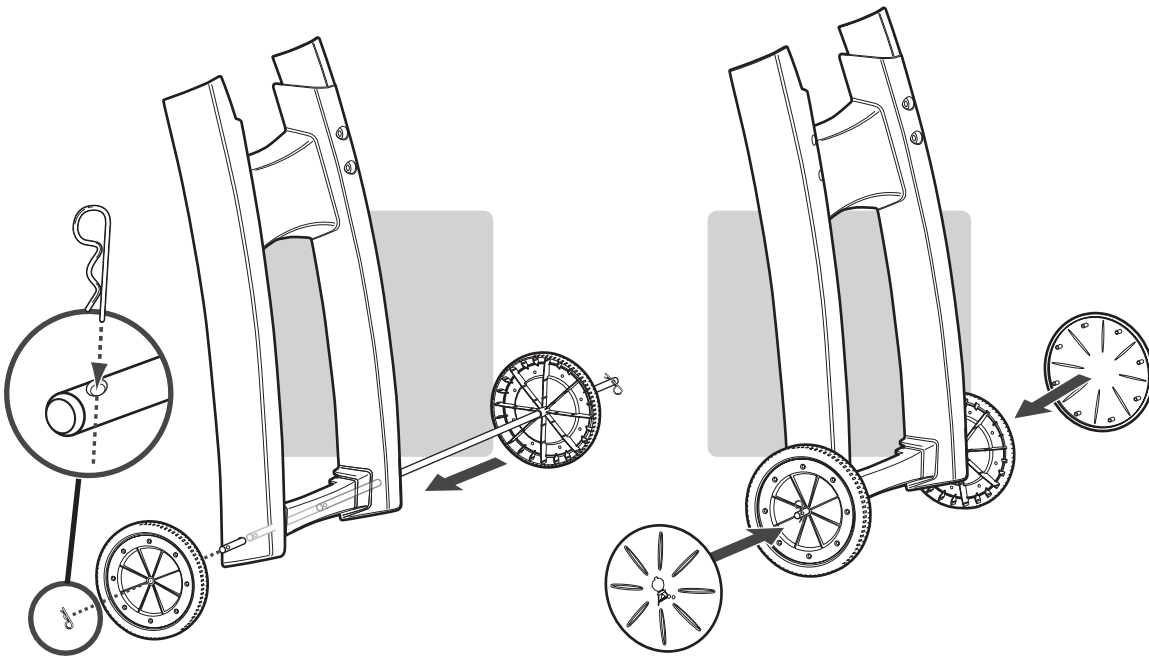
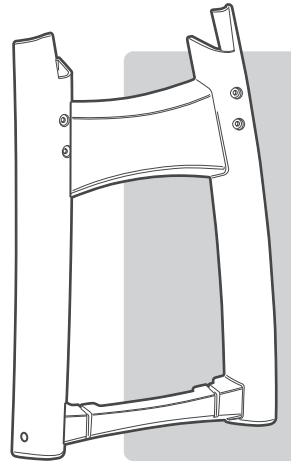
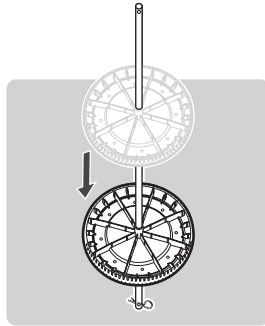
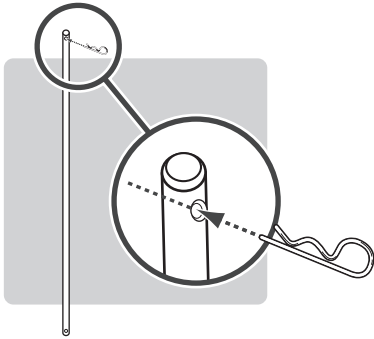

2

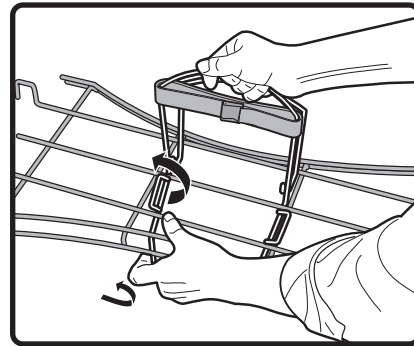
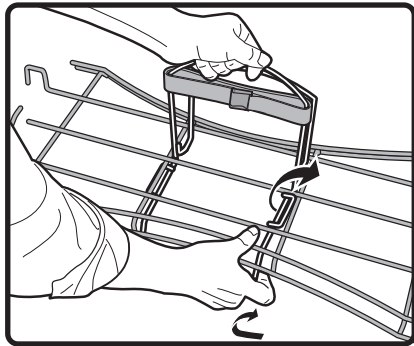
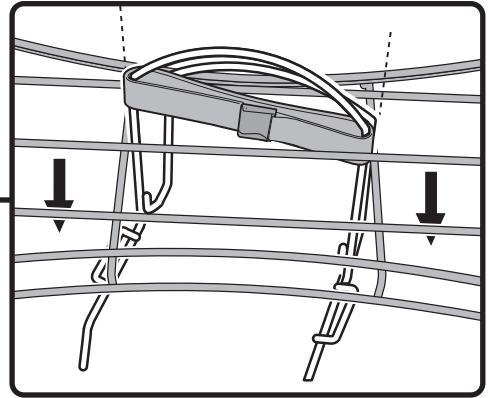
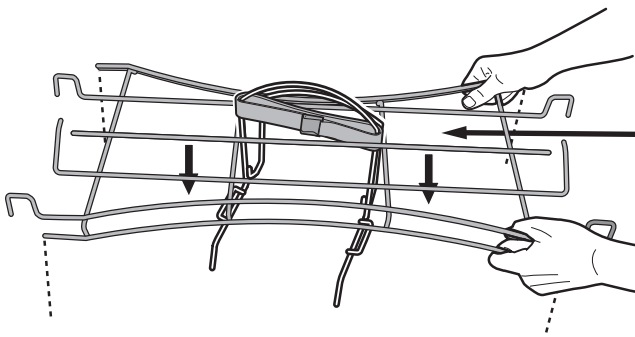
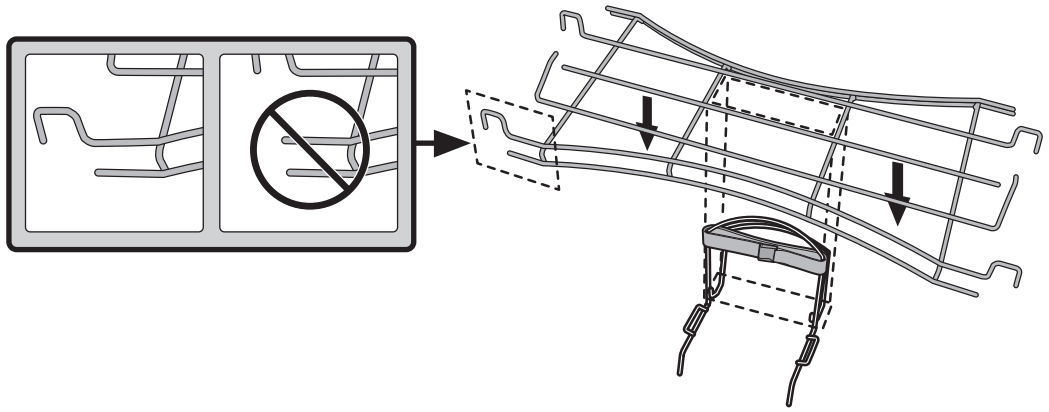

3

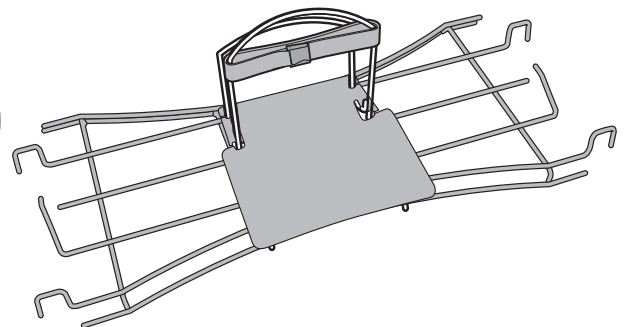
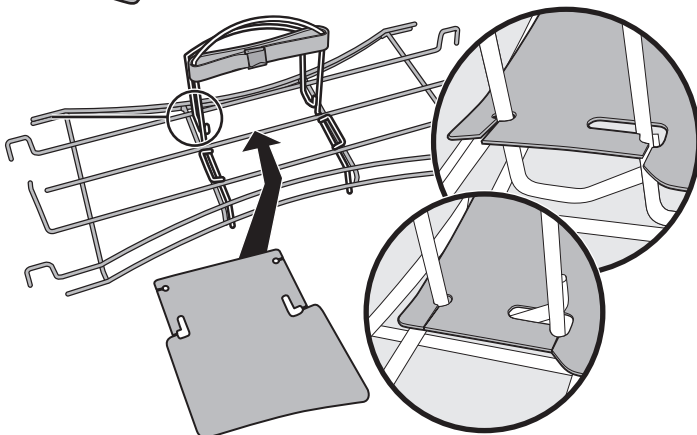
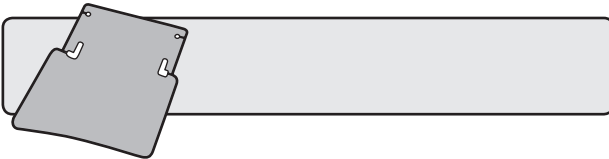

4

△ Place wheel frame on the right.

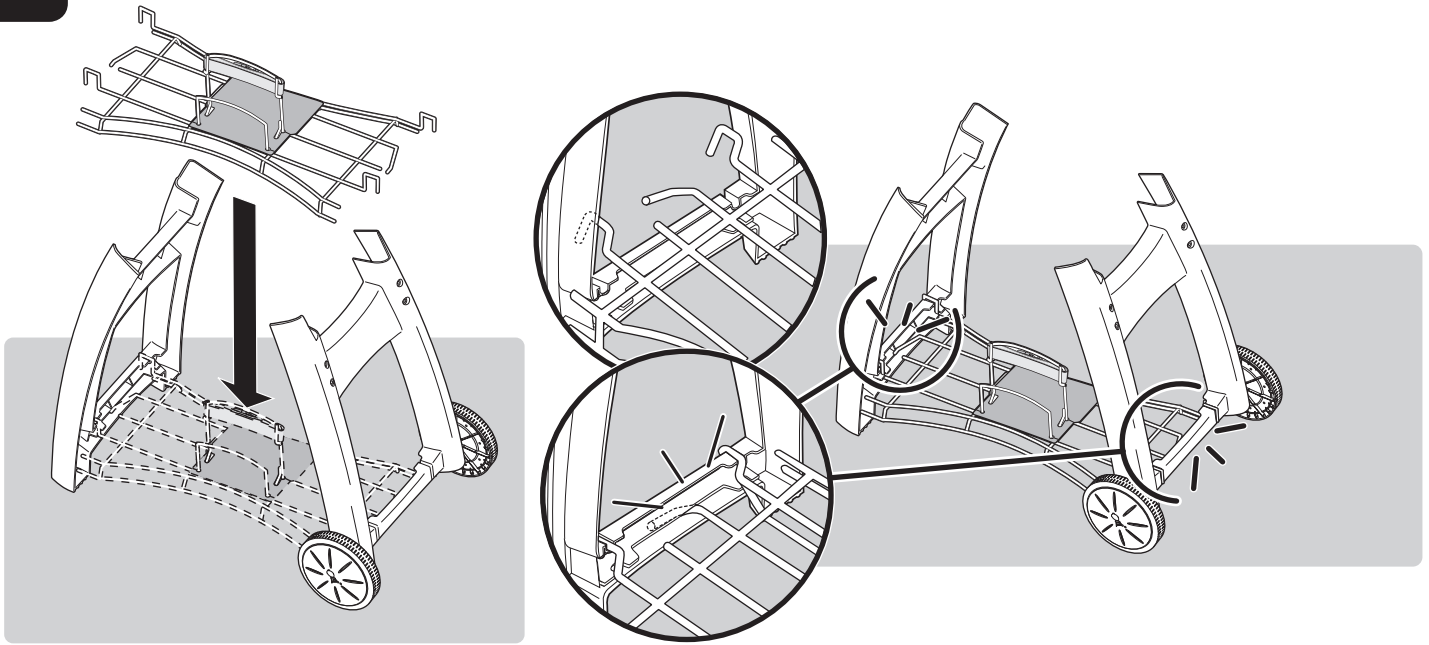

5



8-

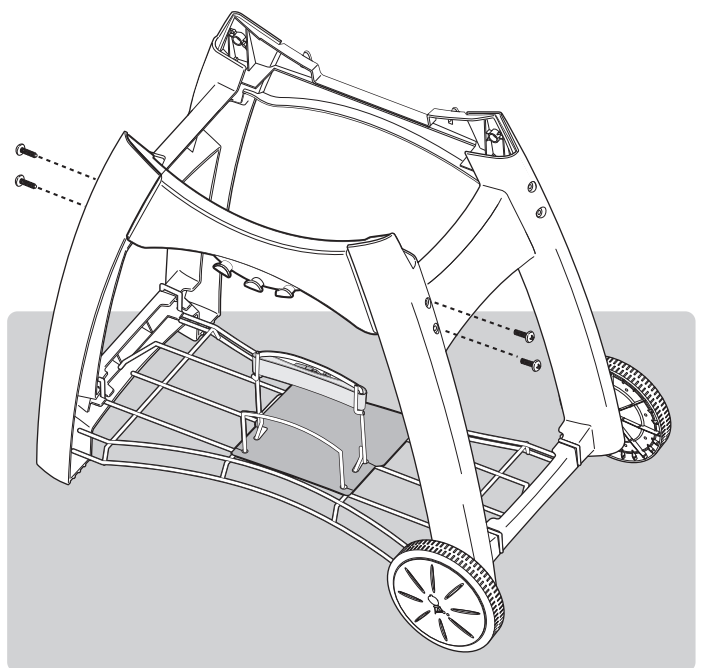
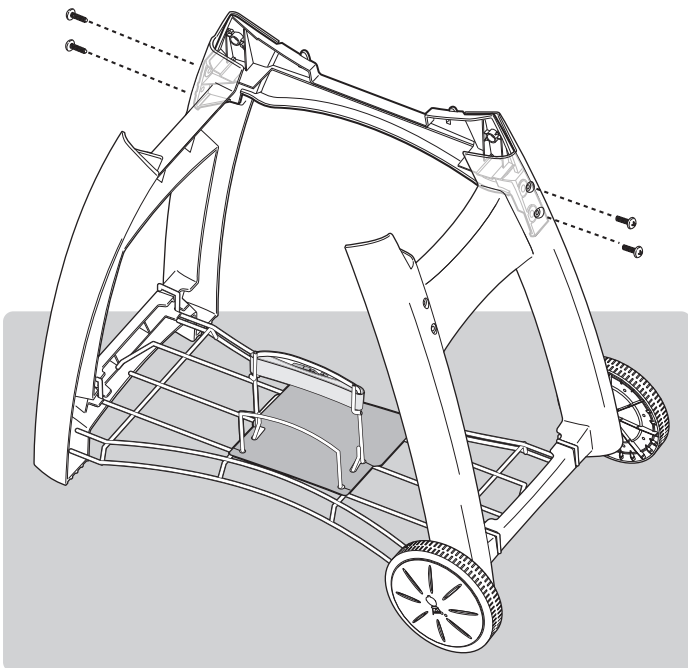

6

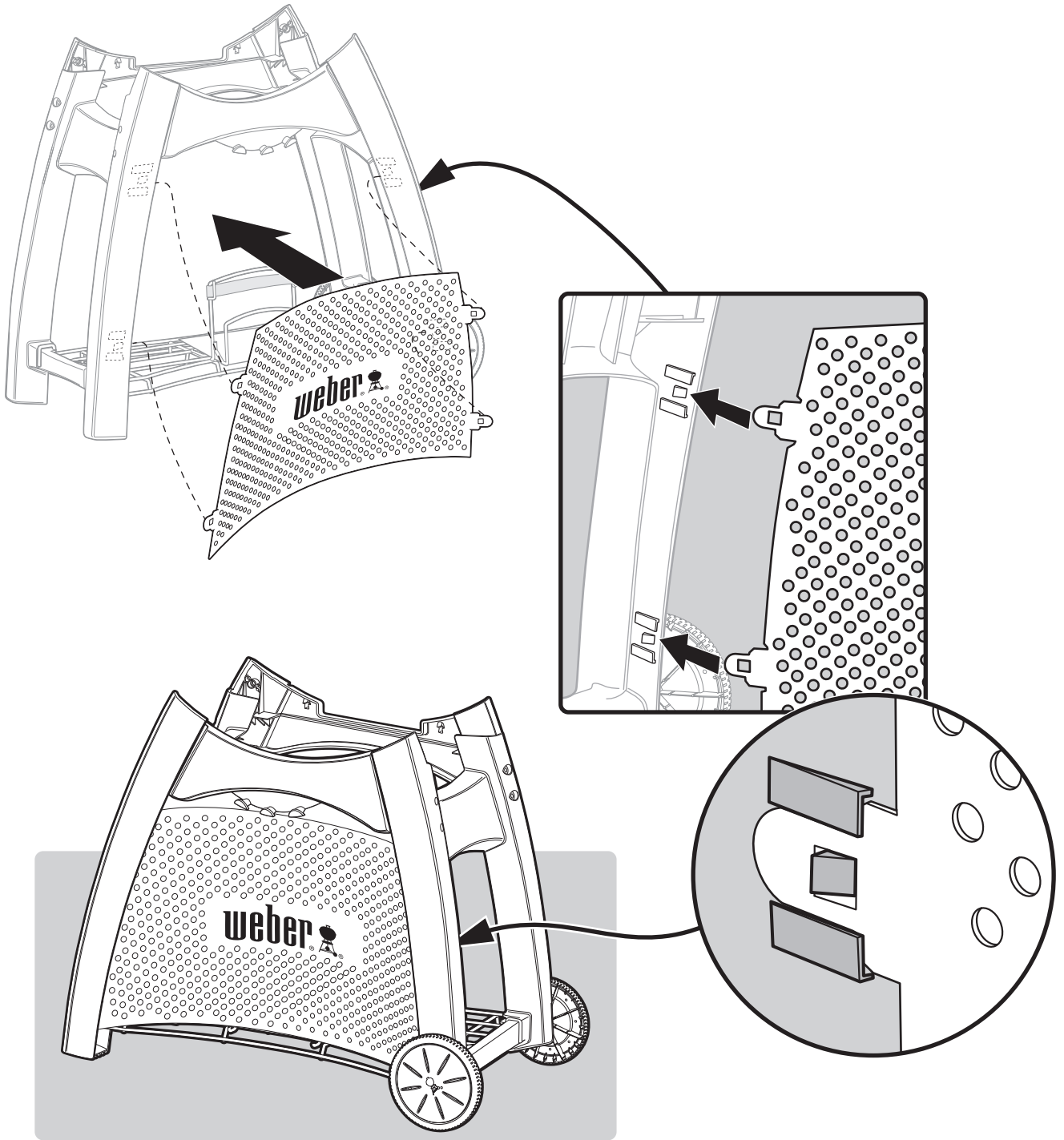

ASSEMBLY

7

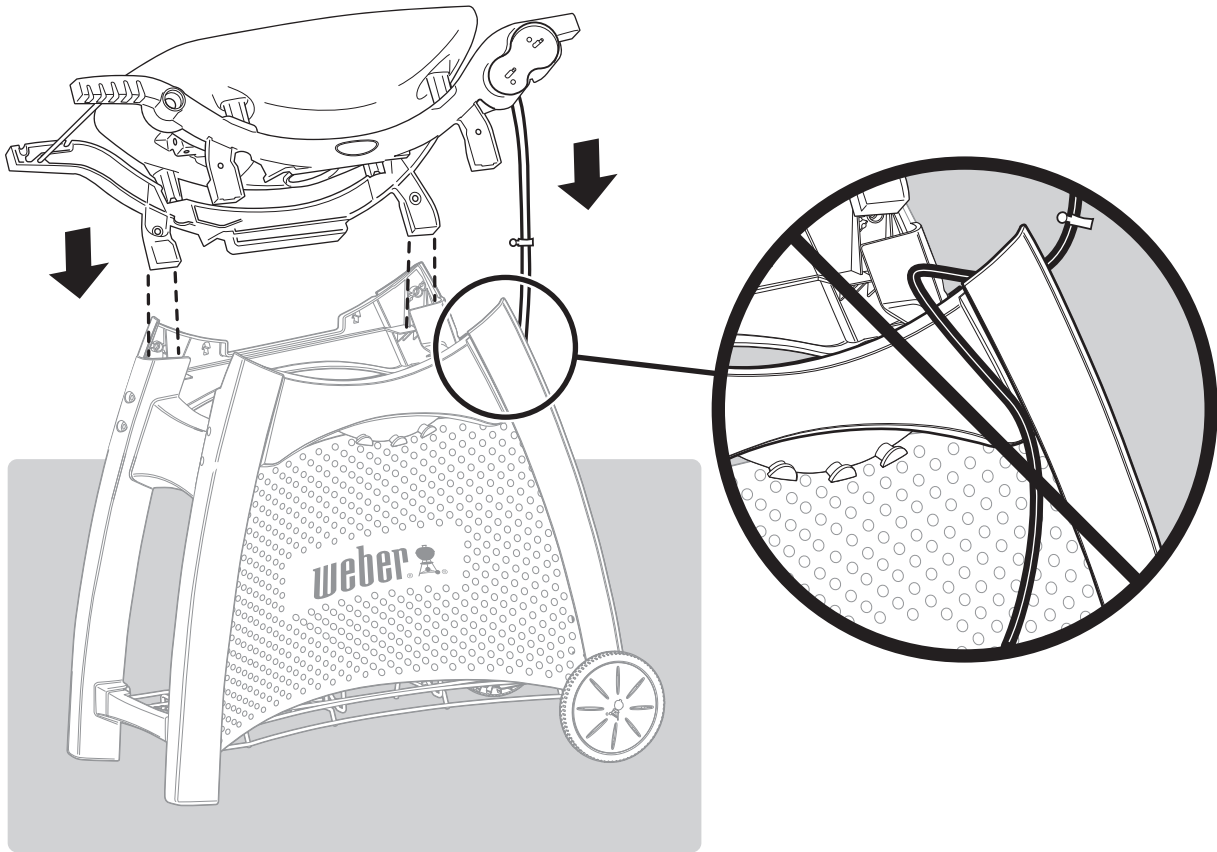

8



4-

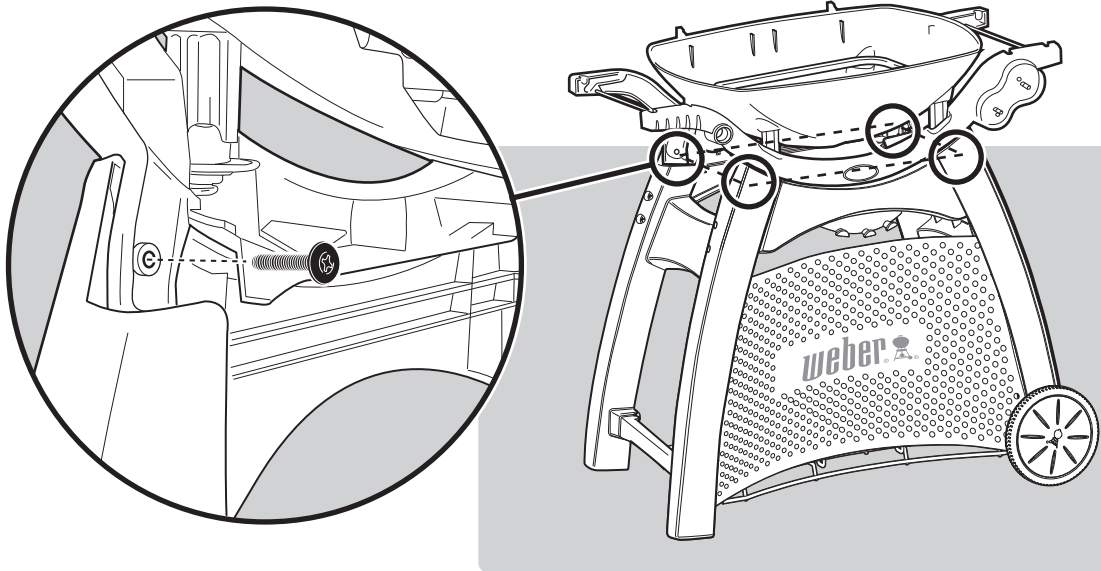

9

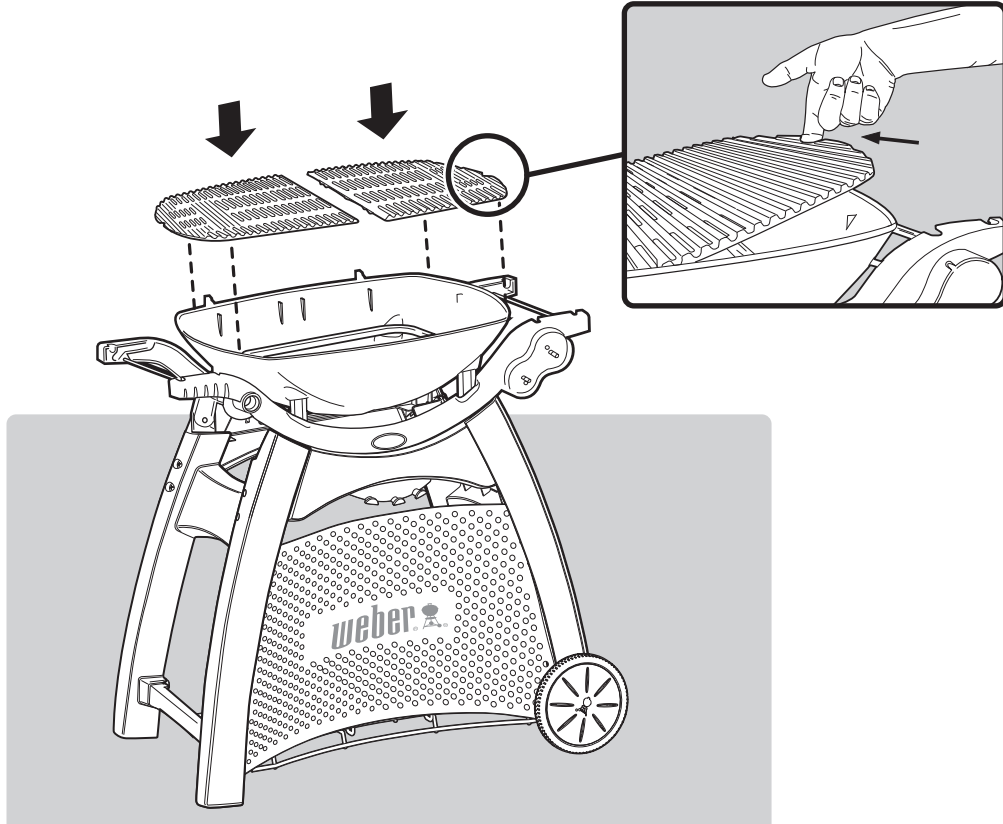

10

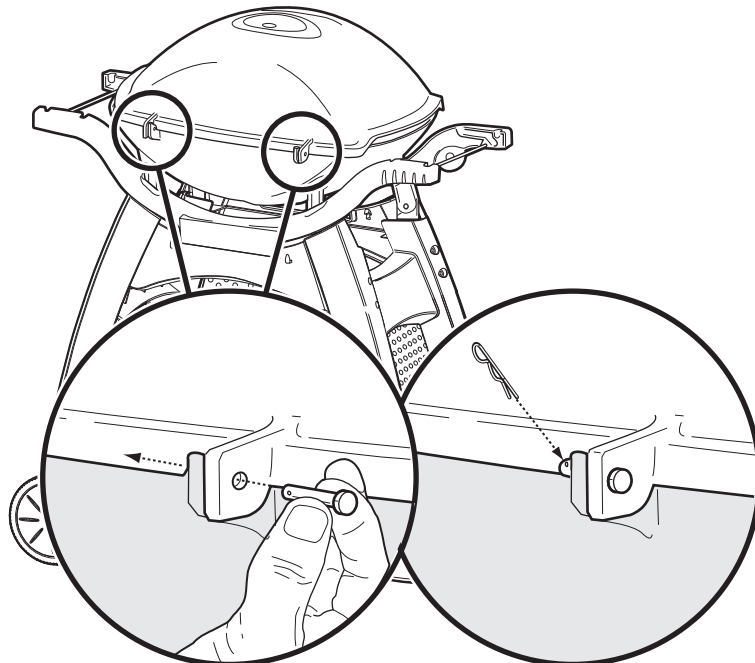

ASSEMBLY

11

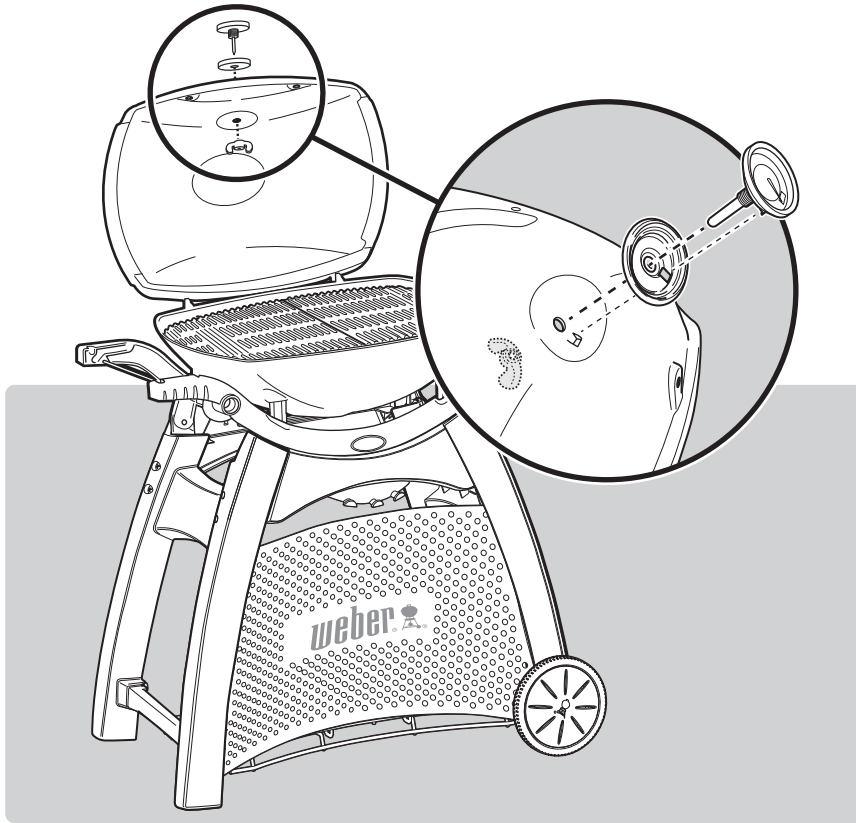

12

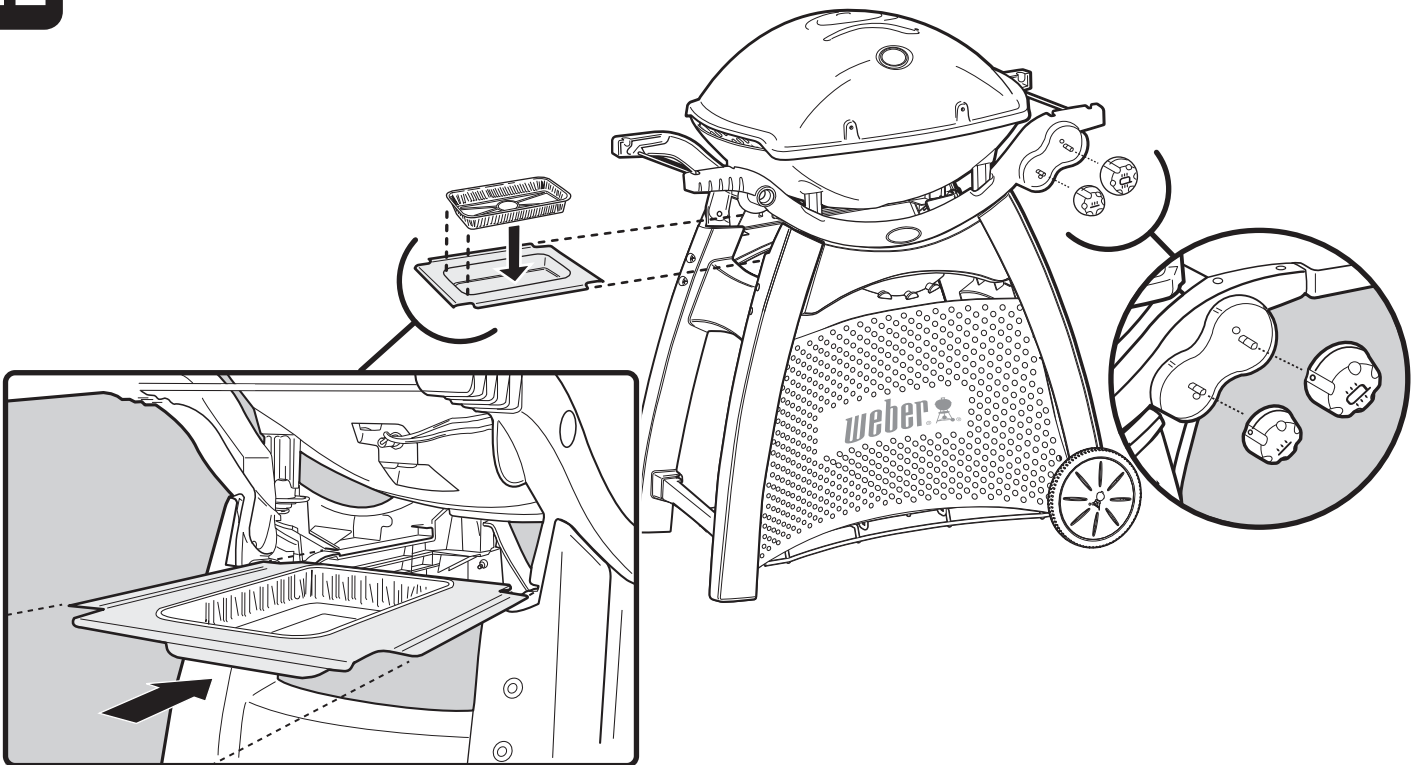

13

- A) Uncoil the hose and regulator of the Weber® Q® 3000/3200.
 - B) Remove leg screw then secure hose and retention clip (1) to cart leg.
- ⚠ WARNING: The hose must be secured to the cart leg by the hose retention clip. Failure to do so could cause damage to hose resulting in a fire or explosion, which can cause serious bodily injury or death and damage to property.**

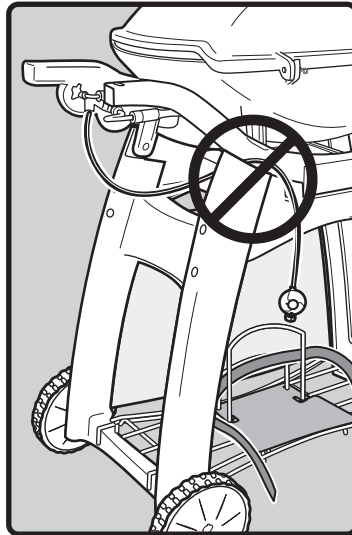
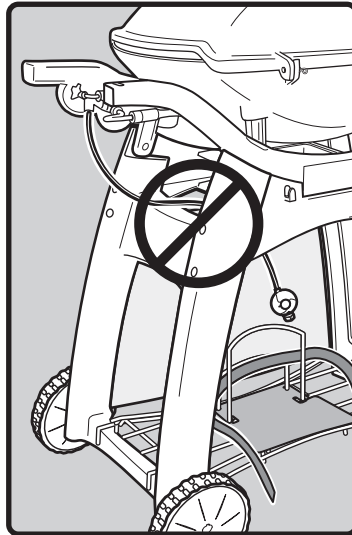
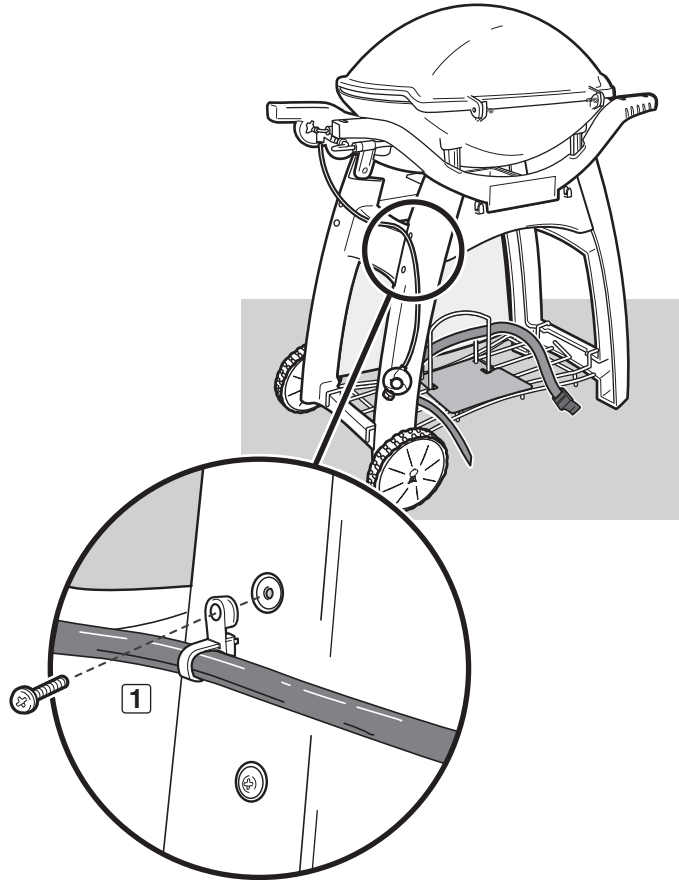

14

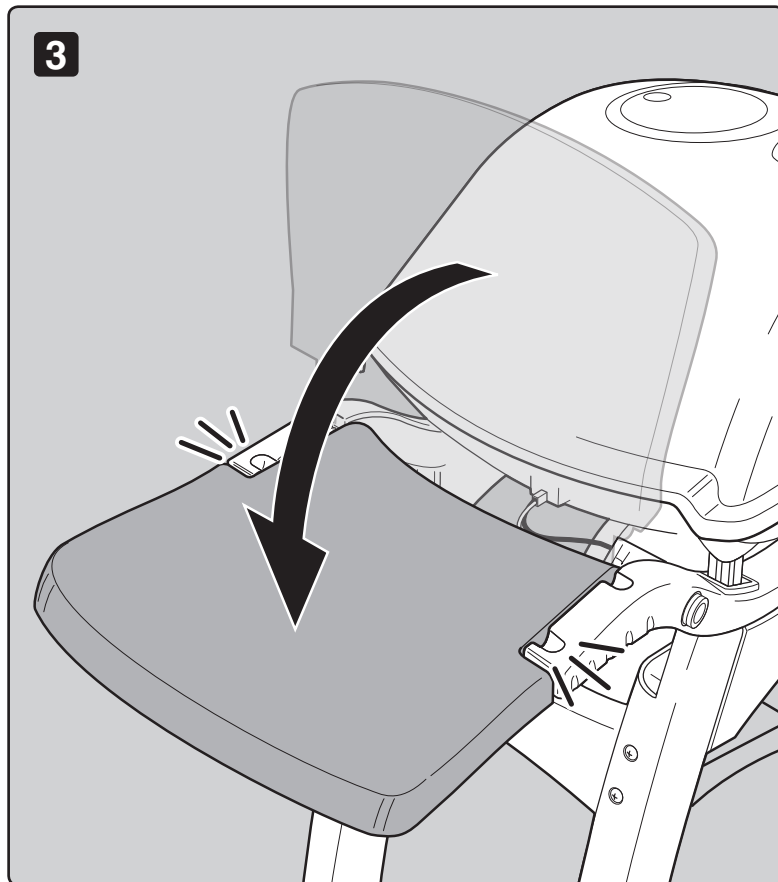
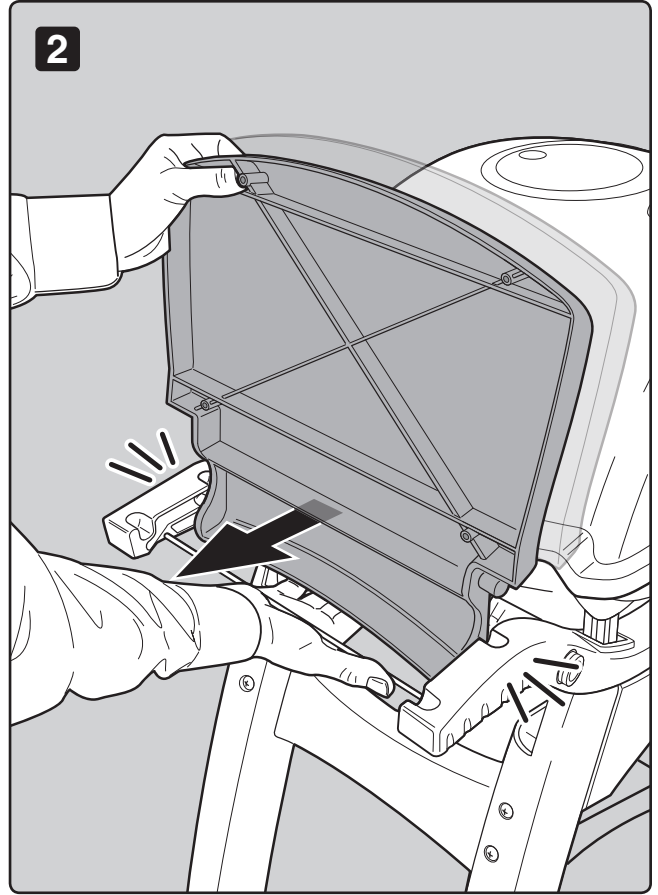
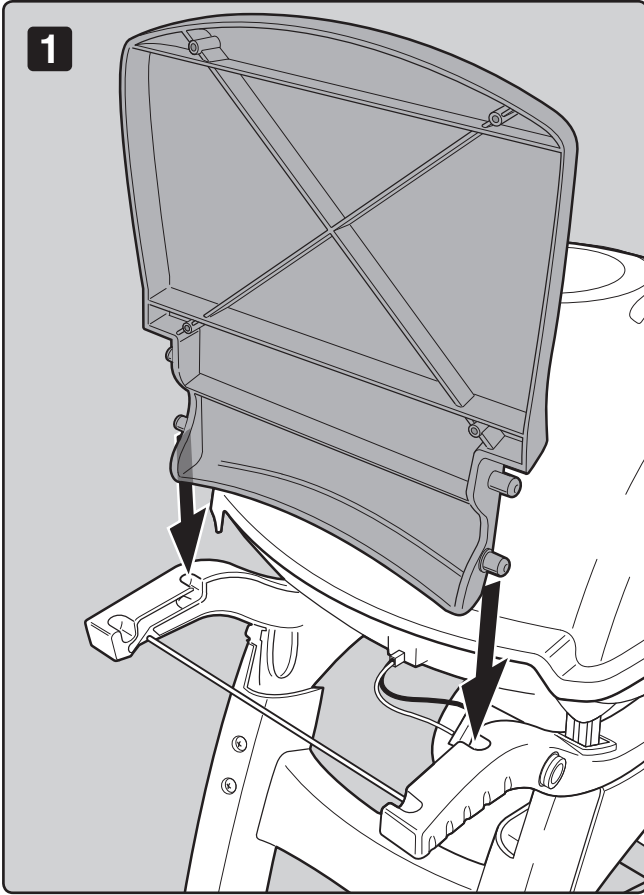

15

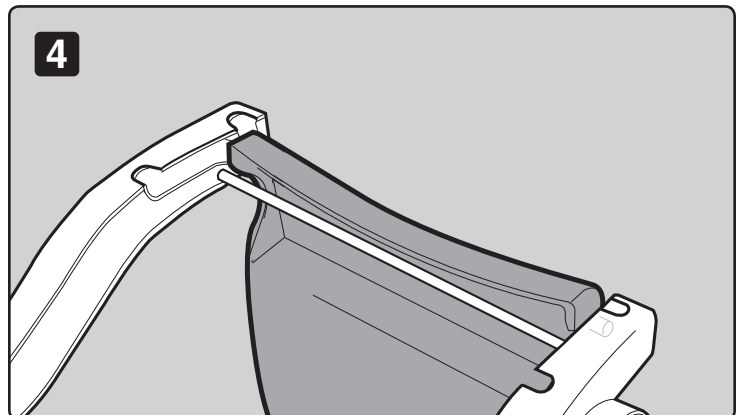
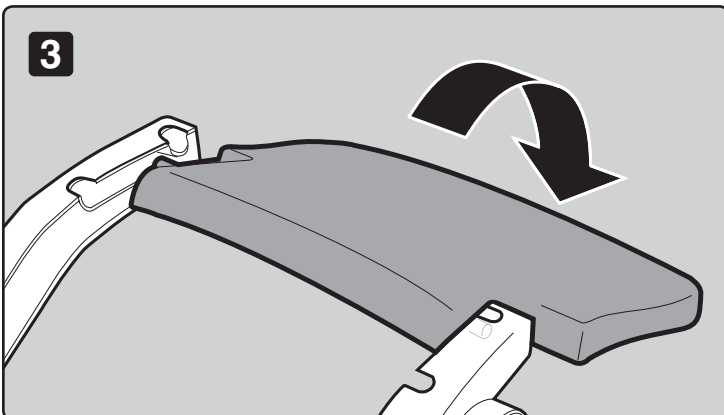
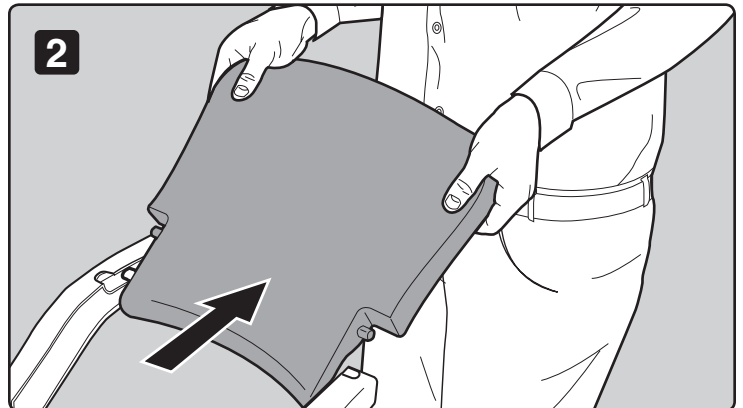
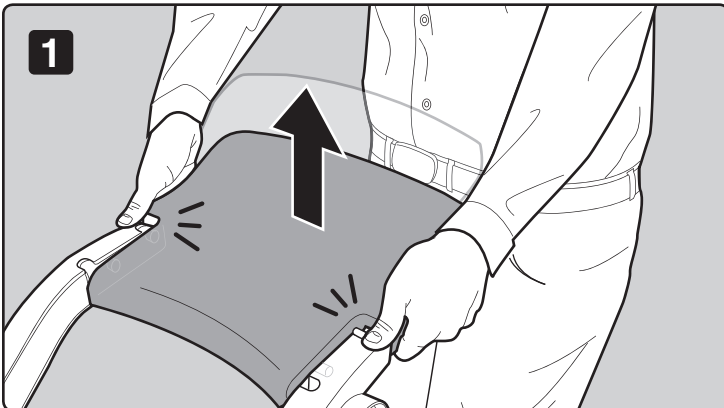
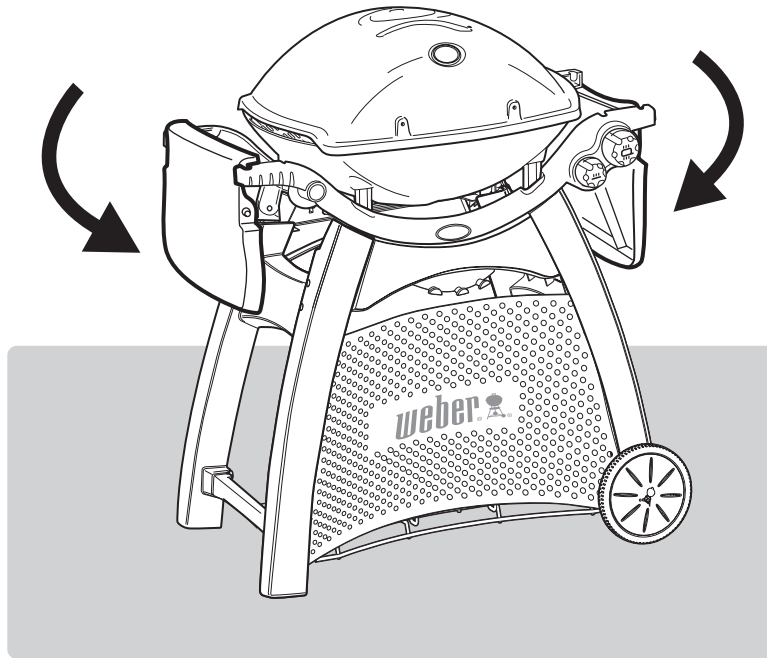

ASSEMBLY

16

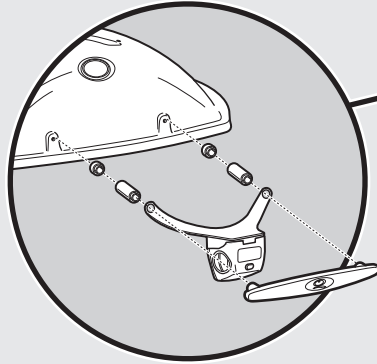
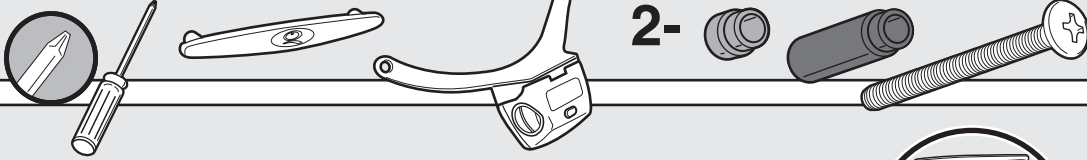

You may hear a rattle in lightpod. This is normal.

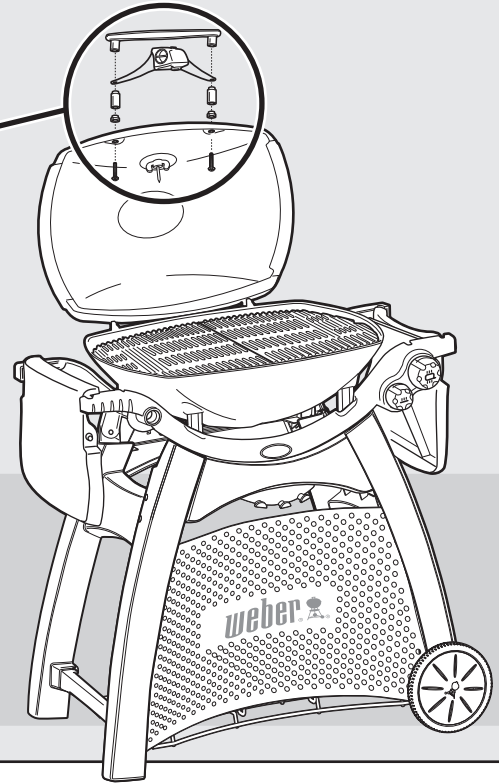

16

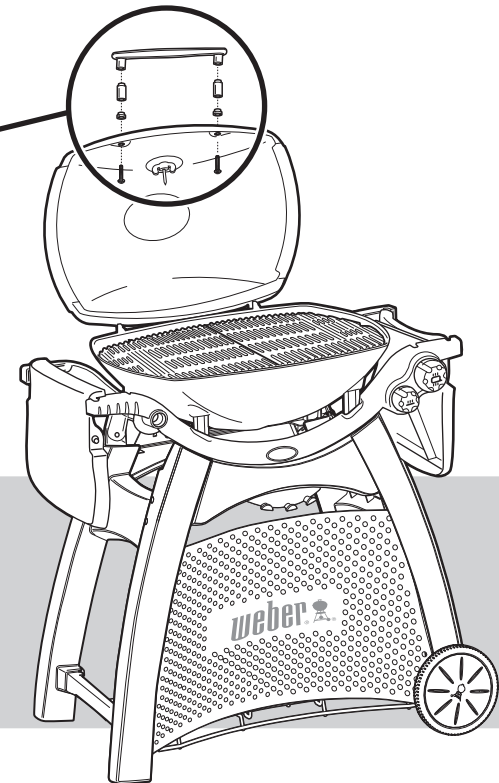
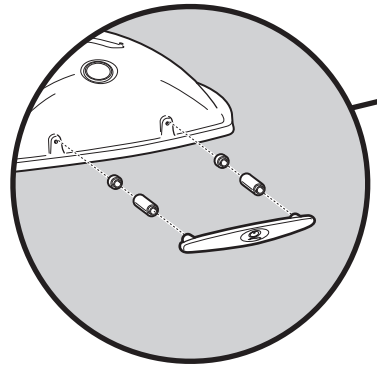
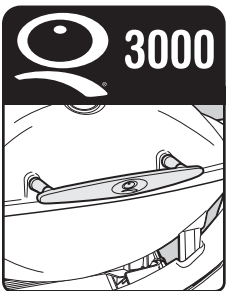

17

3-  + AAA -

 3200

Requires three "AAA" alkaline batteries (not included).

Use alkaline batteries only. Do not mix old and new batteries or different types of batteries (standard, alkaline or rechargeable). If you do not plan to use the Grill Out® Handle Light for a month or more, remove the batteries.

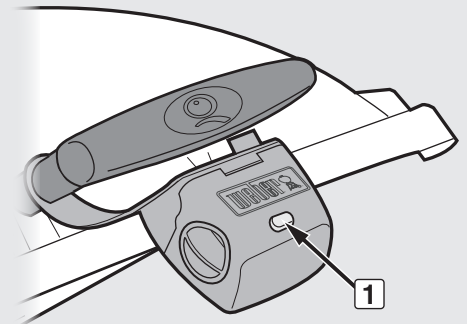
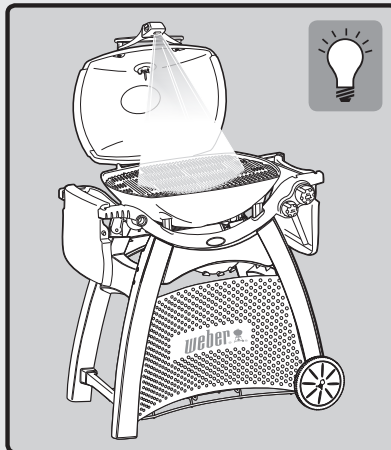
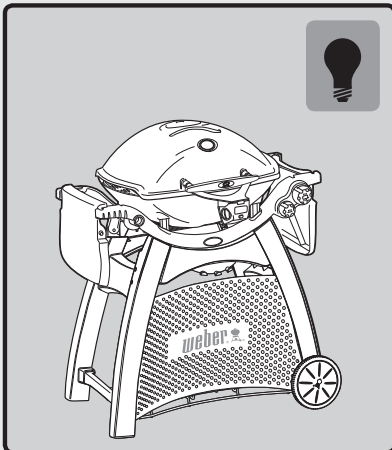
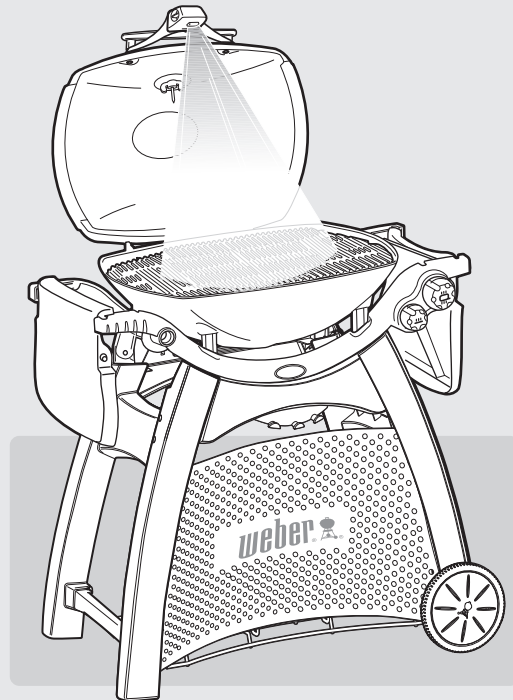
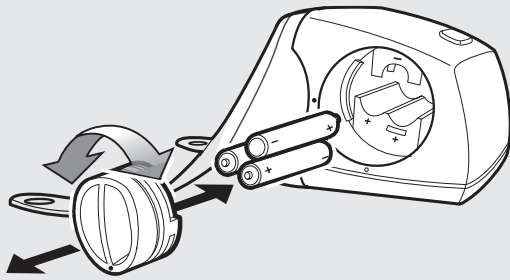

The Grill Out® Handle Light has a "tilt sensor":
Lid up - ON / Lid Closed - OFF. The power button (1) activates or deactivates the "tilt sensor." For daytime use, deactivate the sensor by pressing power button.

ASSEMBLY

18



1-



 3200

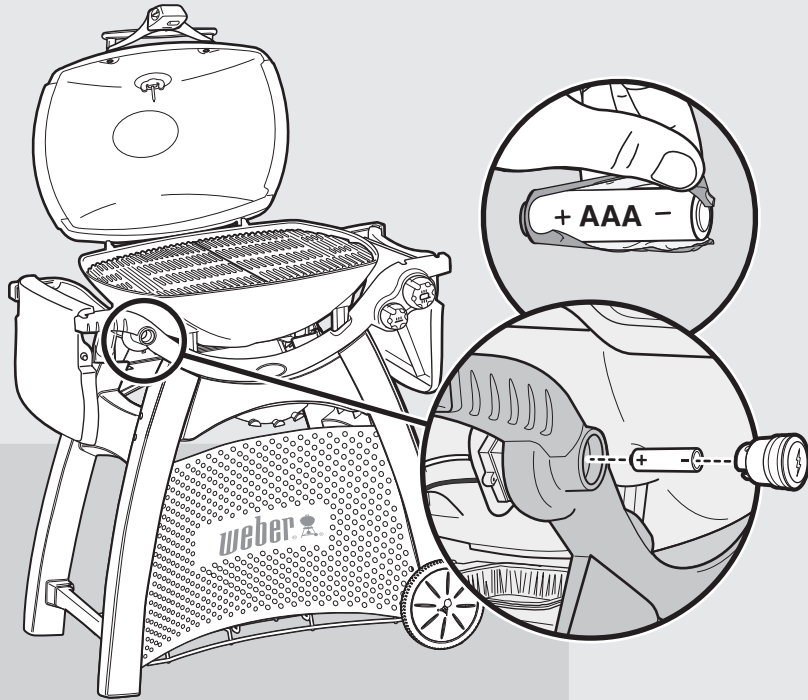

19

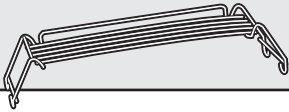

 3200

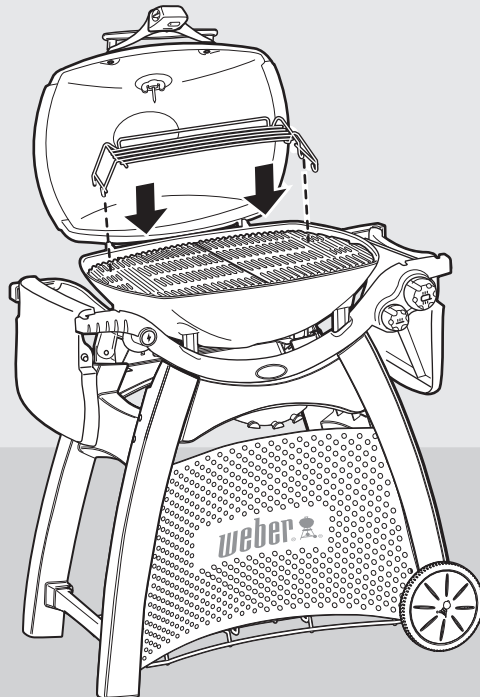

STORAGE FEATURES

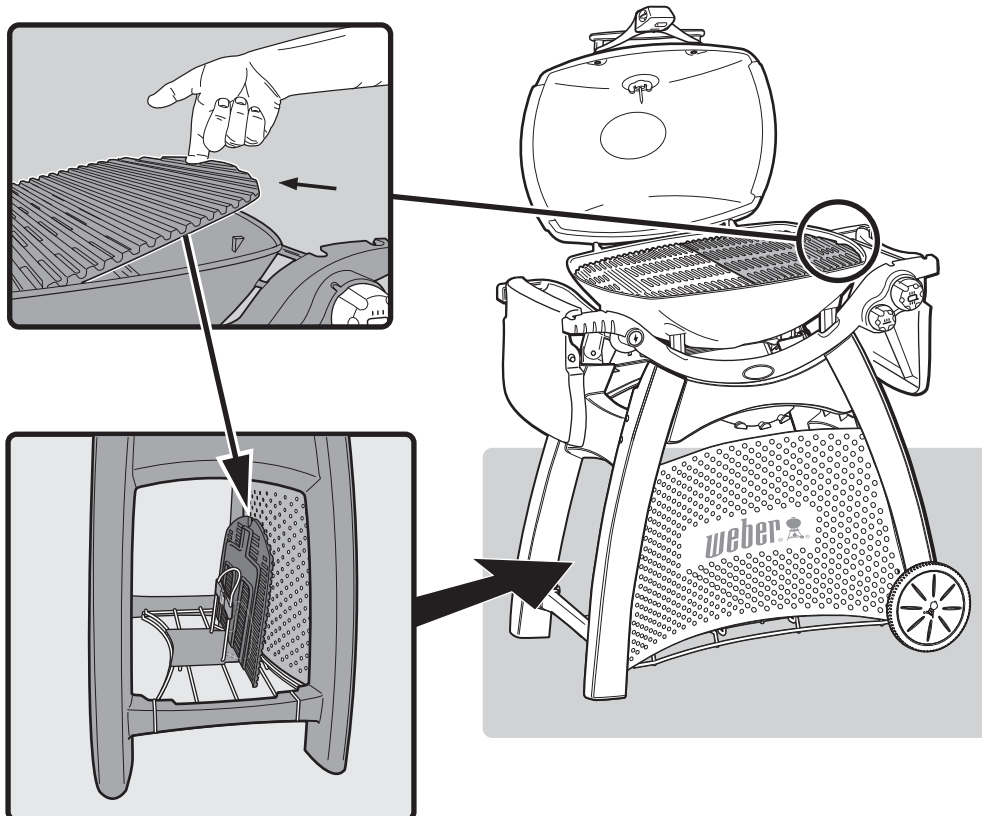
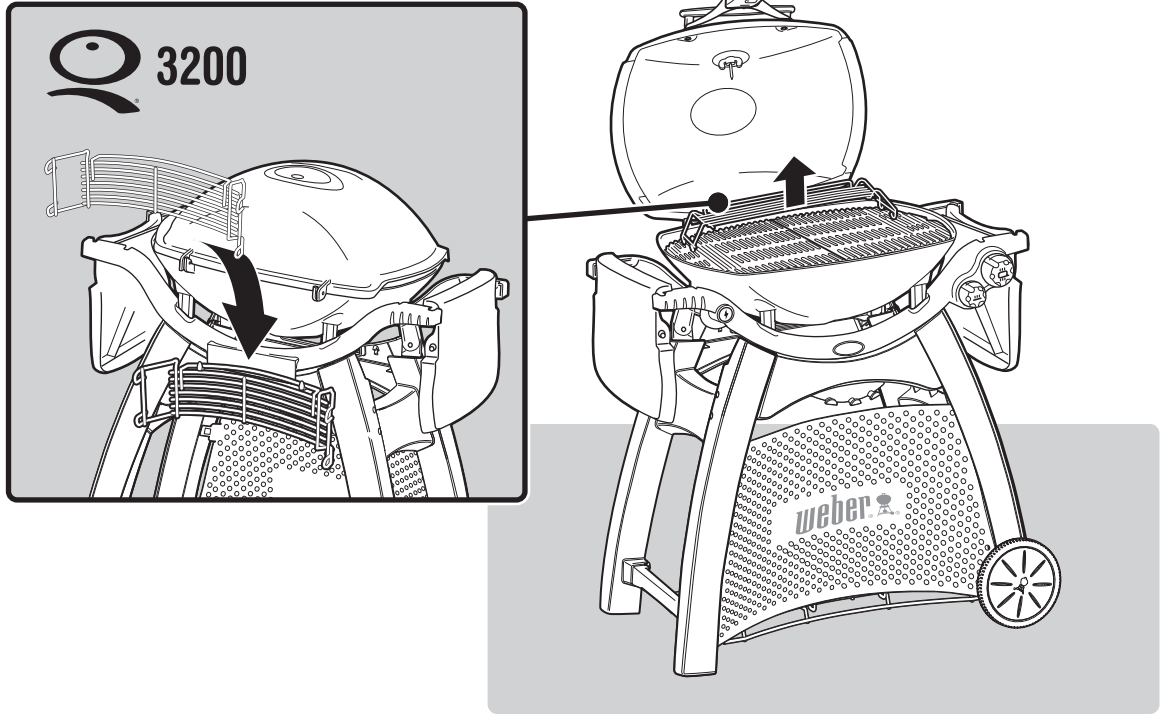

WHAT IS LP GAS?

Liquefied petroleum gas, also called LPG, LP gas, liquid propane, or simply propane or butane, is the flammable, petroleum-based product used to fuel your grill. It is a gas at moderate temperatures and pressure when it is not contained. But at moderate pressure inside a container, such as a cylinder, LPG is a liquid. As pressure is released from the cylinder, the liquid readily vaporizes and becomes LP gas.

- LPG has an odor similar to natural gas. You should be aware of this odor.
- LPG is heavier than air. Leaking LP gas may collect in low areas and resist dispersion.

SAFE HANDLING TIPS FOR LPG CYLINDERS

There are various guidelines and safety factors that you need to keep in mind when using liquefied petroleum gas (LPG). Carefully follow these instructions before using your Weber® gas barbecue.

- Always close the LPG cylinder valve before disconnecting regulator.
- Do not use a damaged cylinder. A dented or rusty cylinder or a cylinder with a damaged valve may be hazardous and should be replaced with a new cylinder immediately.
- Handle "empty" cylinders with the same care as you handle full cylinders. Even when a cylinder is empty of liquid, there may still be gas pressure inside the cylinder.
- Cylinders must be installed, transported, and stored in an upright position. Cylinders should not be dropped or handled roughly.
- Never store or transport the cylinder where temperatures can reach 51° C (the cylinder will become too hot to hold by hand). For example: do not leave the cylinder in a car on a hot day.
- Leak-test the joint where the regulator connects to the cylinder each time a reconnection occurs. For example: test each time the cylinder is refilled and reinstalled.
- Cylinders must be kept out of reach of children.
- Do not connect to natural gas supply (city gas). The valves and orifices are designed exclusively for liquefied petroleum gas.
- The areas around the cylinder must be free and clear from debris.
- The cylinder should not be changed in the proximity of an ignition source.

STORAGE AND NON-USE GUIDELINES

For barbecues that have been stored for a while, it is important to follow these guidelines:

- The gas must be turned off at the LPG cylinder when the Weber® gas barbecue is not in use.

⚠ WARNING: Make sure that the cylinder valve is closed when the barbecue is not in use.

- If storing the Weber® gas barbecue indoors, first DISCONNECT the gas supply and store the cylinder outdoors in a well-ventilated space.
- Do not store a disconnected cylinder in a building, garage, or any other enclosed area.
- If you do not disconnect the cylinder from the Weber® gas barbecue, be sure to keep both the barbecue and the cylinder outdoors in a well-ventilated area.
- Check that the areas under the cookbox and the removable catch pan are free from debris that might obstruct the flow of combustion or ventilation air.
- The Weber® gas barbecue should be checked for gas leaks and any obstructions in the burner tubes before it is used.
- The spider/insect screens should also be checked for any obstructions.

LPG CYLINDER REQUIREMENTS

- Use only a 3kg-13kg LPG cylinder.

REGULATOR CONNECTIONS & REQUIREMENTS

- In the United Kingdom, this appliance must be fitted with a regulator complying with BS 3016, having a nominal output of 37 millibars. (Supplied with barbecue.)
- The length of hose must not exceed 1.5 metres.
- Avoid kinking the hose.
- Change the flexible hose when national regulations stipulate this as a requirement.
- Any parts sealed by the manufacturer must not be altered by the user.
- Any modification of the appliance may be dangerous.
- Only a nationally approved low-pressure hose and regulator must be used.
- Replacement pressure regulators and hose assemblies must be those specified by the outdoor cooking gas appliance manufacturer.
- Be sure the regulator is mounted with the small vent hole pointed downward so that it will not collect water. This vent should be free of dirt, grease, bugs, etc.

COUNTRY	GAS TYPE & PRESSURE
Bulgaria, Cyprus, Czech Republic, Denmark, Estonia, Finland, Hungary, Iceland, Latvia, Lithuania, Malta, Netherlands, Norway, Romania, Slovak Republic, Slovenia, Sweden, Turkey	I ₃ B/P - 30 mbar
Belgium, France, Greece, Ireland, Italy, Luxembourg, Portugal, Spain, Switzerland, United Kingdom	I _{3*} - 28-30 / 37 mbar
Poland	I ₃ B/P - 37 mbar
Austria, Germany	I ₃ B/P - 50 mbar

CONSUMPTION DATA				
	Propane kW	Butane kW	Propane g/h	Butane g/h
Weber® Q® 3000	6,1	6,36	434	453
Weber® Q® 3200	6,1	6,36	434	453

REPLACEMENT HOSE, REGULATOR AND VALVE ASSEMBLY

⚠ IMPORTANT NOTICE: We recommend that you replace the gas hose assembly on your Weber® gas barbecue every five years. Some countries may have requirements that the gas hose be replaced within less than five years, in which case that country's requirement would take precedence.

For replacement hose, regulator, and valve assemblies, contact the Customer Service Representative in your area using the contact information on our web site. Log on to www.weber.com®.

LPG CYLINDER INSTALLATION

WHERE DOES THE LPG CYLINDER GO?

The type and size of cylinder you purchase will determine its placement for installation. There are two installation options: secured to the cylinder bracket on the bottom rack of the cart or placed on the ground behind the barbecue.

⚠ DANGER

Do not store an extra (spare) or disconnected gas supply cylinder under or near this barbecue.

REQUIREMENTS FOR INSTALLATION ON CART

The LPG cylinder can be installed on the bottom rack of cart if the cylinder does not exceed the maximum size requirements for installation on cart:

Cylinder Capacity: 6 kg maximum

Cylinder Height: 465 mm maximum

The cylinder must be secured to the cylinder bracket on the bottom rack of cart using the supplied strap (1).

⚠ WARNING: If the cylinder exceeds the maximum cylinder size requirements for installing on the cart, do not attempt to place or connect the cylinder on the cart. Place and connect the cylinder on the ground behind the barbecue. Failure to do so could cause damage to the hose resulting in a fire or explosion, which can cause serious bodily injury or death, and damage to property.

Several possible cylinder models approved for installation on cart are illustrated, with dimensions included.

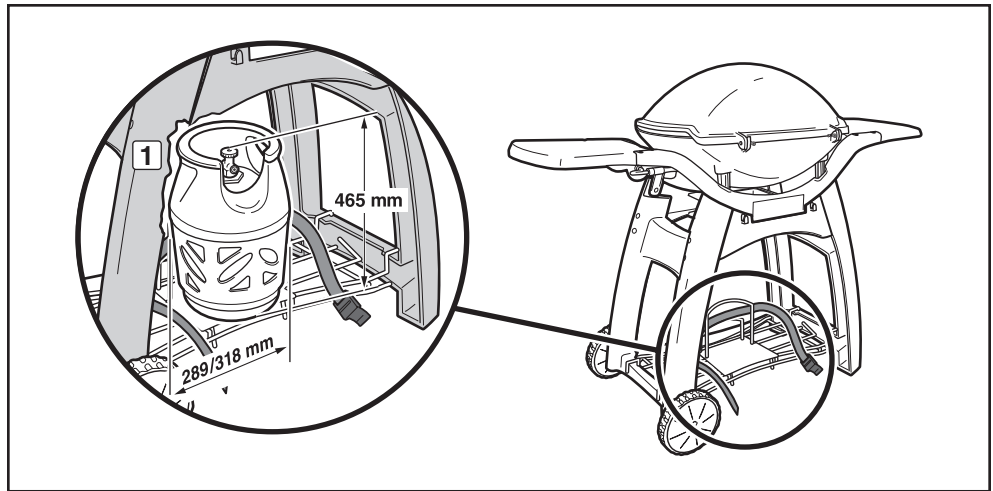

CALOR 5 kg

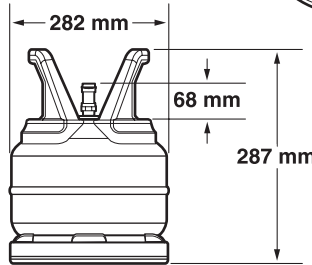

PRIMAGAZ 5.2 kg

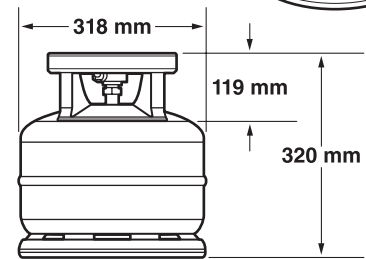
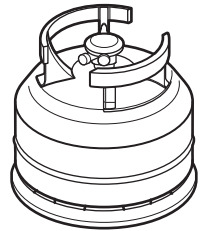

BP 5 kg

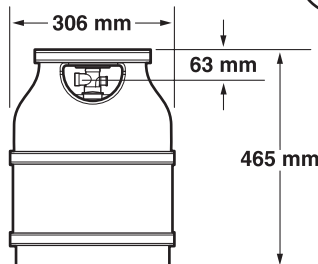

BUTAGAZ 6 kg

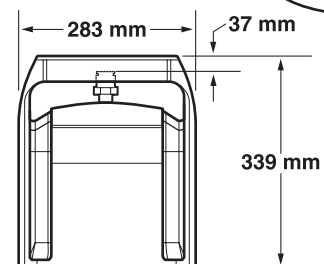
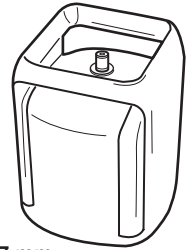

LPG CYLINDER INSTALLATION

INSTALLATION ON CART

- A) Make sure the cylinder rest is installed to prevent scratching the bottom rack. Lift and place the LPG cylinder on the cylinder rest (1).
 - B) Turn the cylinder so the opening of the valve is facing the right side or back of barbecue.
 - C) Secure the cylinder to the cylinder bracket using the cylinder strap (2).
- ⚠ WARNING: The cylinder must be secured to the cylinder bracket when barbecue is in use.**
- D) Connect the regulator to the cylinder. Refer to "CONNECTING THE REGULATOR TO THE LPG CYLINDER."

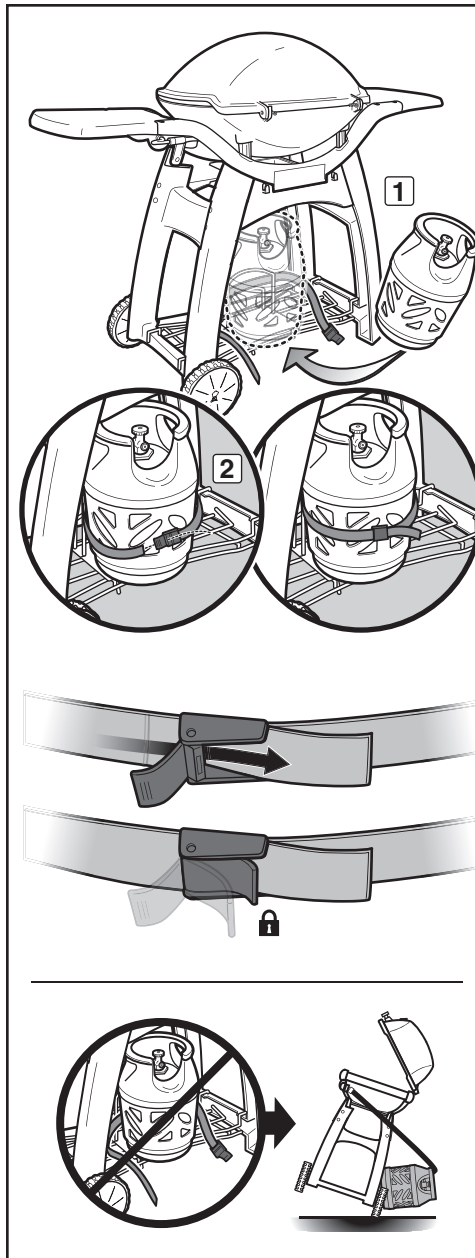

Maximum LPG cylinder capacity when INSTALLED ON CART under the barbecue is 6 kg.

The length of hose must not exceed 1.5 metres.

REQUIREMENTS FOR INSTALLATION ON GROUND

If the LPG cylinder you have exceeds the maximum size requirements for installation on cart, the cylinder must be placed on the ground behind the barbecue. The maximum size requirements for cylinders installed on ground are:

- Cylinder Capacity:** 13 kg maximum
Cylinder Height: 587 mm maximum
Cylinder Width: 306 mm maximum

INSTALLATION ON GROUND

- A) Place the LPG cylinder on the ground, behind the barbecue (3).
- B) Turn the cylinder so the opening of the valve is facing the right side or back of barbecue.
- C) Connect the regulator to the cylinder. Refer to "CONNECTING THE REGULATOR TO THE LPG CYLINDER."

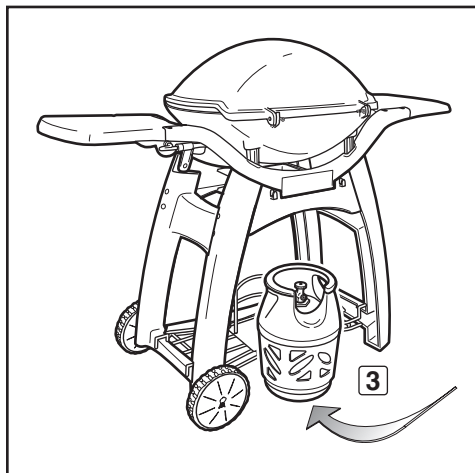

Maximum LPG cylinder capacity when INSTALLED ON GROUND is 13 kg.

The length of hose must not exceed 1.5 metres.

CONNECTING THE REGULATOR

WHAT IS A REGULATOR?

Your Weber® gas barbecue is equipped with a pressure regulator, which is a device to control and maintain uniform gas pressure as gas is released from the LPG cylinder.

CONNECTING THE REGULATOR TO THE LPG CYLINDER

Only use LPG cylinders with a minimum capacity of 3 kg and a maximum capacity of 13 kg.

A) Remove screw from right cart leg of cart. Insert hose retention clip. Reinstall screw.

⚠ WARNING: The hose must be secured to the cart leg by the hose retention clip. Failure to do so could cause damage to hose resulting in a fire or explosion, which can cause serious bodily injury or death and damage to property.

B) Connect regulator to cylinder.

⚠ WARNING: Make sure that the LPG cylinder or regulator valve is closed.

Some regulators push ON to connect and pull OFF to disconnect; others have a nut with a left-hand thread that connects to the cylinder valve. Identify your regulator type and follow one of the connection instructions specific to that regulator.

Connect by Turning Clockwise

Screw regulator onto cylinder by turning fitting clockwise (1). Position the regulator so that the vent hole (2) faces down.

Connect by Turning Anti-Clockwise

Screw regulator onto cylinder by turning fitting anti-clockwise (3) (4).

Connect by Turning Lever/Snapping into Position

Turn regulator lever (5) clockwise to the off position. Push regulator down on cylinder valve until regulator snaps into position (6).

Connect by Sliding Collar

Make sure regulator lever is in the off position (7) (10). Slide the collar of the regulator up (8) (11). Push the regulator down onto the cylinder valve and maintain pressure. Slide collar down to close (9) (12). If regulator does not lock, repeat procedure.

Note: The regulator illustrations shown in this manual may not be similar to the regulator you are using for your barbecue, due to different country or regional regulations.

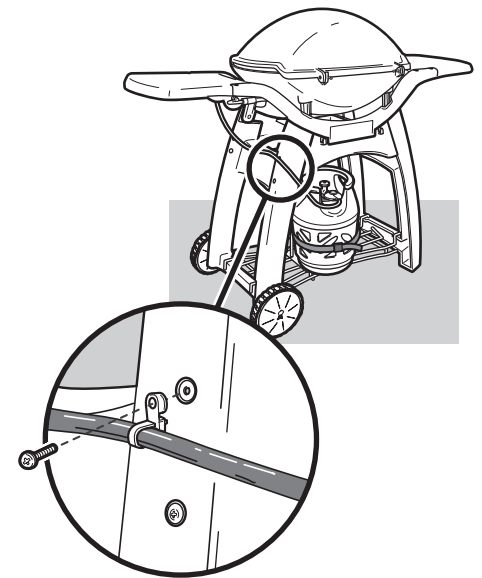
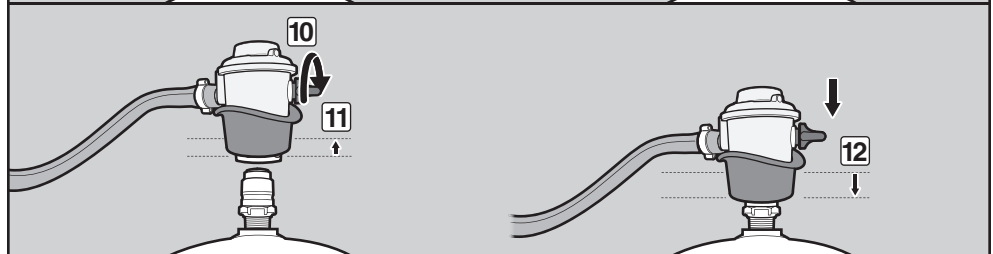
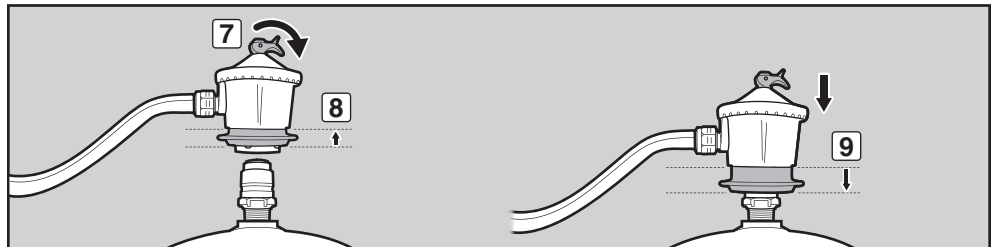
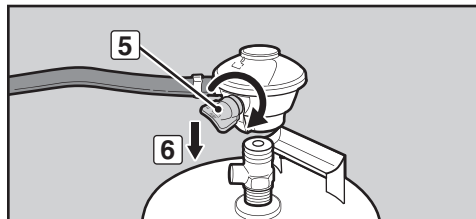
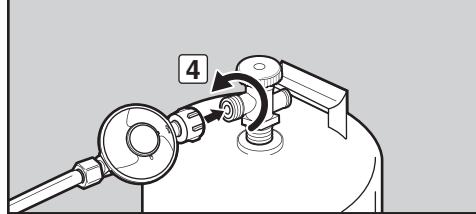
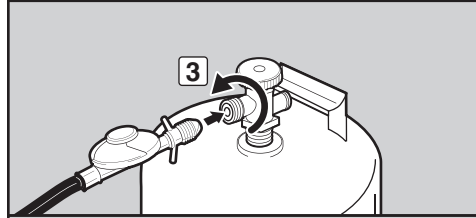
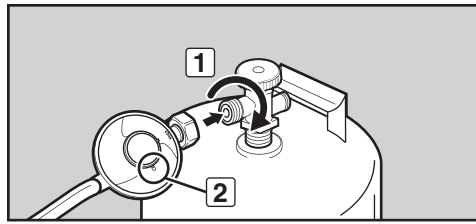

PREPARING TO USE YOUR BARBECUE

WHAT IS A LEAK CHECK?

The fuel system in your barbecue features connections and fittings. A leak check is a reliable way to make sure that no gas is escaping from any of the connections or fittings.

Although all factory-made connections have been thoroughly checked for gas leaks, it's important to perform a leak check before using your barbecue for the first time, as well as anytime you disconnect and reconnect a fitting and each time you perform routine maintenance.

⚠ DANGER

Do not use an open flame to check for gas leaks. Be sure there are no sparks or open flames in the area while you check for leaks. Sparks or open flames will result in a fire or explosion, which can cause serious bodily injury or death and damage to property.

⚠ WARNING: The gas connections of your gas barbecue have been factory-tested. We do, however, recommend that you leak-check all gas connections before operating your gas barbecue.

⚠ WARNING: Perform these leak checks even if your barbecue was dealer- or store-assembled.

⚠ WARNING: You should check for gas leaks every time you disconnect and reconnect a gas fitting.

NOTE: All factory-made connections have been thoroughly checked for gas leaks and the burners have been flame-tested. As a safety precaution, however, you should check all fittings for leaks before using your Weber® gas barbecue. Shipping and handling may loosen or damage a gas fitting.

CHECKING FOR GAS LEAKS

You will need: A spray bottle or brush or rag and a soap and water solution. (You can make your own soap and water solution by mixing 20% liquid soap with 80% water; or, you can purchase leak check solution in the plumbing section of any hardware store.)

A) Make sure **ALL** burner control knobs are turned off. Check by pushing burner control knobs in and turning them clockwise until they stop.

B) Turn gas supply on at source.

Identify your regulator type. Follow the instructions for that regulator.

Turn Valve

Turn cylinder valve anti-clockwise (1) (2) (3).

Move Lever

Move regulator lever to the on position (4) (5) (6).

⚠ WARNING: Do not ignite burners when leak-checking.

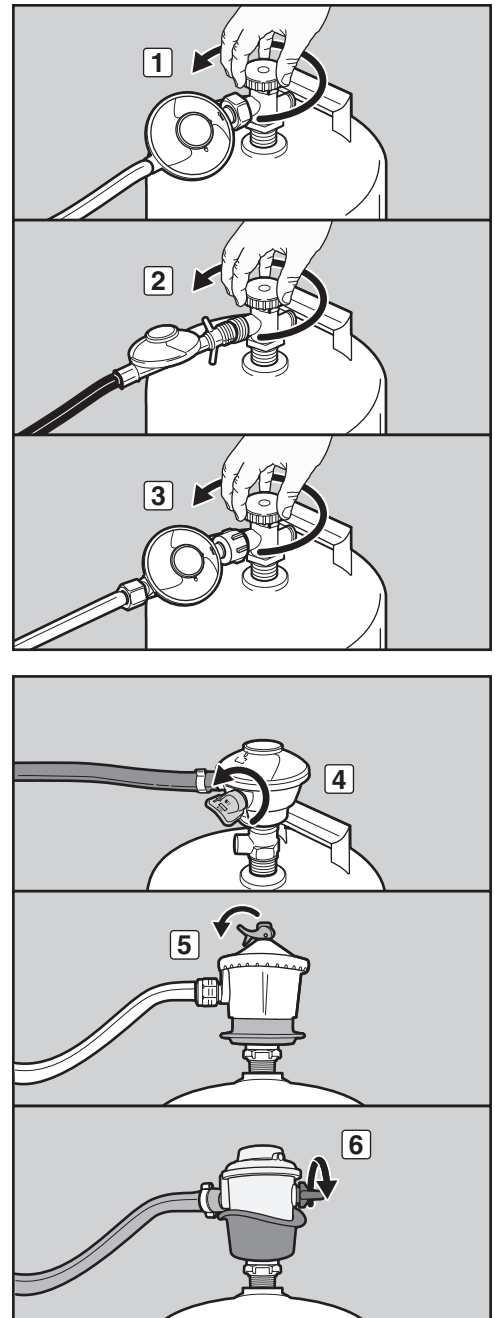

PREPARING TO USE YOUR BARBECUE

C) To check for leaks, wet fittings with the soap and water solution, using a spray bottle, brush or rag. If bubbles form, or if a bubble grows, there is a leak. Apply the soap and water solution to the following connections:

- a) Manifold-to-regulator hose connection (7).
- b) Valve-to-outside burner tube gas line connection (8).
- c) Valve-to-inside burner tube gas line connection (9).
- d) Regulator-to-cylinder connection (10).
- e) Regulator hose-to-regulator connection (11).

⚠ WARNING: If there is a leak at connections (7, 8, 9, 10 or 11), turn off the gas. DO NOT OPERATE THE BARBECUE. Contact the Customer Service Representative in your area using the contact information on our web site. Log onto www.weber.com®.

D) When leak checking is complete, turn gas supply off at the source and rinse connections with water.

NOTE: Since some leak test solutions, including soap and water, may be slightly corrosive, all connections should be rinsed with water after checking for leaks.

Now you are ready to use your barbecue.

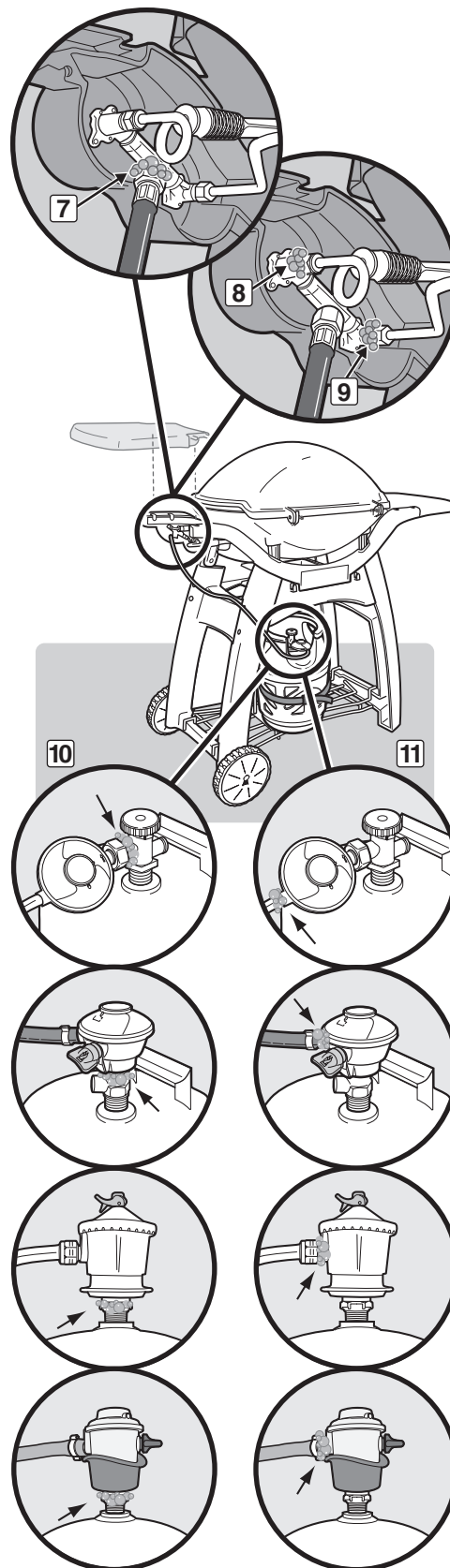

DISCONNECTING THE REGULATOR

DISCONNECTING THE REGULATOR FROM THE LPG CYLINDER

A) Remove the LPG cylinder by shutting off the gas supply and disconnecting the hose and regulator assembly from the cylinder.

⚠ WARNING: Make sure that the cylinder or regulator valve is closed.

Identify your regulator type. Follow the disconnection instructions for that regulator.

Disconnect by Turning Anti-Clockwise

Unscrew regulator from cylinder by turning fitting anti-clockwise (1).

Disconnect by Turning Clockwise

Unscrew regulator from cylinder by turning fitting clockwise (2) (3).

Disconnect by Turning Lever

Turn regulator lever clockwise (4) to the off position. Push in on regulator lever (5) until it releases from cylinder (6).

Disconnect by Sliding Collar

Make sure regulator lever is in the off position (7) (9). Slide the collar of the regulator up (8) (10) to disconnect from the cylinder.

B) Exchange empty cylinder for a full cylinder.

REFILLING THE LPG CYLINDER

We recommend that you refill the LPG cylinder before it is completely empty. To refill, take LPG cylinder to a "Gas Propane" dealer.

RECONNECTING THE LPG CYLINDER

Refer to "CONNECTING THE REGULATOR TO THE LPG CYLINDER."

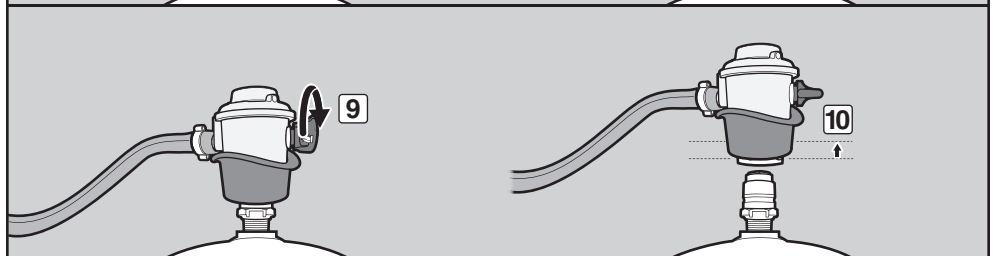
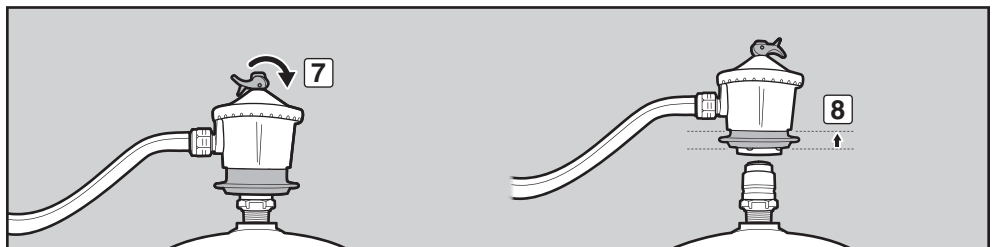
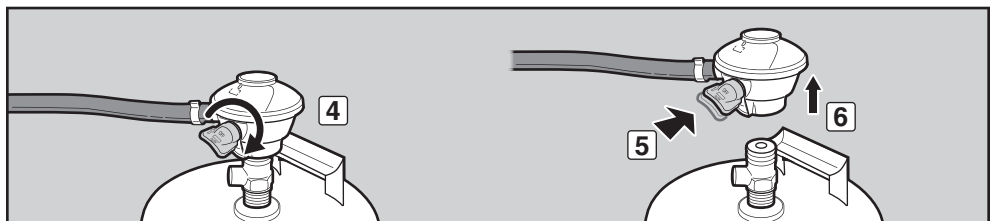
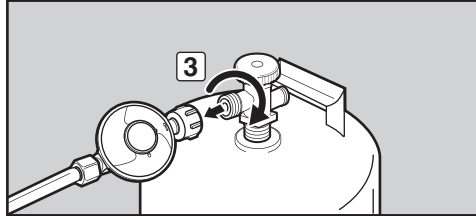
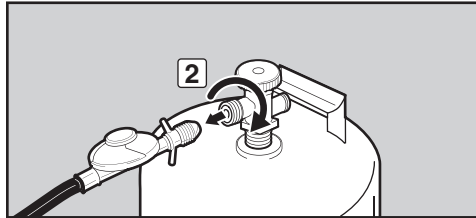
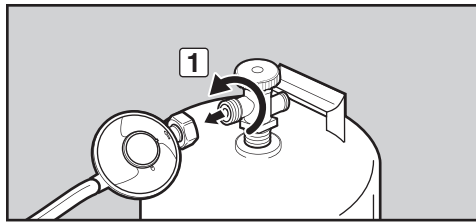

SAFETY FIRST

It's a good idea to get in the habit of performing a few safety checks before barbecuing.

Safety must be considered when you are deciding where to place and operate your barbecue. Be sure to read the following warnings before installing or using your barbecue.

WARNINGS:

- ⚠ This appliance is intended for outdoor use only and should never be used in garages and roofed or enclosed porches or verandas.
- ⚠ Your Weber® gas barbecue must never be used under an unprotected combustible roof or overhang.
- ⚠ Your Weber® gas barbecue is not intended to be installed in or on caravans and/or boats.
- ⚠ Flammable materials should not be present within approximately 60 cm of the barbecue. This includes the top, bottom, back or sides of the barbecue.
- ⚠ Keep the cooking area clear of flammable vapours and liquids such as petrol, alcohol, etc., and combustible materials.
- ⚠ This appliance gets very hot. Take special care when children or elderly people are present.
- ⚠ Do not move the appliance when it is alight.
- ⚠ Use this barbecue only on a flat and level surface.

REMOVABLE CATCH PAN AND DISPOSABLE DRIP PAN

Your barbecue was built with a grease collection system, which funnels grease away from food and into a removable catch pan. For your convenience, you can also line the removable catch pan with a Weber® disposable drip pan, which will help keep the removable catch pan cleaner longer.

Cleaning the removable catch pan is just as important as cleaning the cookbox. Check the removable catch pan for grease build-up each time you use your barbecue. Remove excess grease with a plastic scraper (1). Wash the removable catch pan with warm, soapy water and rinse with water.

- ⚠ **WARNING:** Check the removable catch pan or disposable drip pan for grease build-up before each use. Remove excess grease to avoid a grease fire. A grease fire can cause serious bodily injury or damage to property.
- ⚠ **CAUTION:** Do not line the cookbox, removable catch pan or disposable drip pan with aluminium foil.

HOSE INSPECTION

The hose should be inspected routinely for any signs of cracking (2).

- ⚠ **WARNING:** Check hose before each use of barbecue for nicks, cracking, abrasions or cuts. If the hose is found to be damaged in any way, do not use the barbecue. Replace using only Weber® authorised replacement hose. Contact the Customer Service Representative in your area using the contact information on our web site. Log onto www.weber.com®.

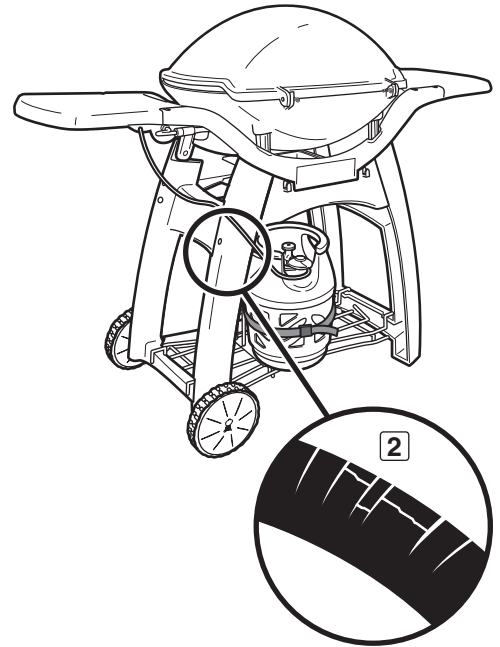
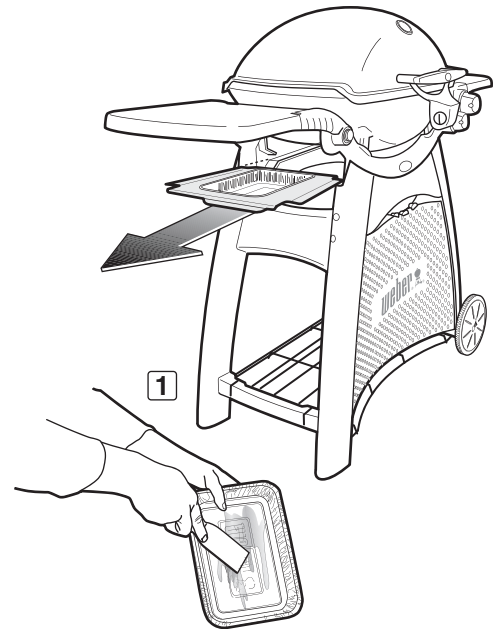

METHODS OF BURNER IGNITION

There are two ways to ignite the burner. The first is by using the ignition system built into your barbecue. The second is with a match.

Next are the steps for igniting your barbecue using the ignition system. On the following page are steps for igniting your barbecue with a match.

BURNER IGNITION

A) Open the barbecue lid (1).

⚠ DANGER

Failure to open the lid before igniting the barbecue's burners, or not waiting five minutes to allow the gas to clear if the barbecue does not light, may result in an explosive flare-up which can cause serious bodily injury or death.

- B) Make sure **ALL** burner control knobs are turned off (2). Check by pushing burner control knobs in and turning them clockwise until they stop.
- C) Turn on the cylinder valve using one of the appropriate options based on your cylinder and regulator type.
- D) Light the outside burner by pushing the large burner control knob in and turning it counterclockwise to start/high (†) position (3).
- E1) Push the red igniter button several times, so it clicks each time (4) (Q® 3000).

OR

- E2) Push and hold in the electronic igniter button (5) (Q® 3200). You will hear the igniter clicking.
- F) Check that the burner is lit by looking through the cooking grates. You should see a flame.

⚠ WARNING: While igniting the barbecue or cooking, never lean over open barbecue.

⚠ WARNING: If the burner fails to ignite within five seconds, stop, turn the burner control knob to off and wait five minutes to allow the gas to clear before you try again or light with a match.

- G) After the outside burner is lit, you can turn on the inside burner. Push in the small burner control knob and turn it to start/high (†) position (6). The inside burner will then be ignited by the outside burner.

TO EXTINGUISH BURNER

Push each burner control knob in and turn it clockwise to the off (O) position. Turn gas supply off at the source.

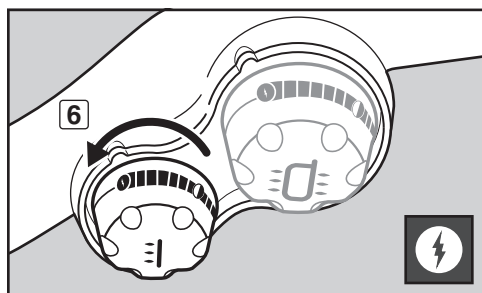
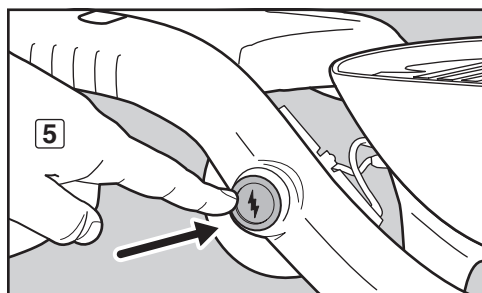
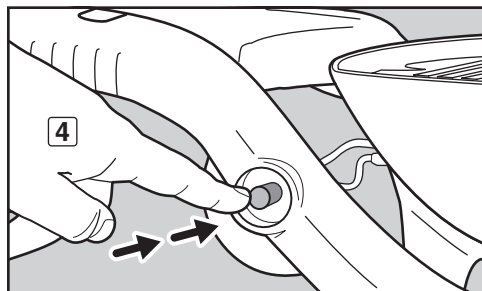
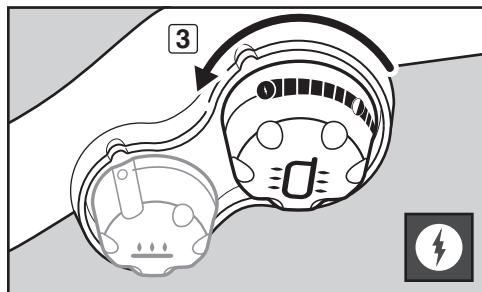
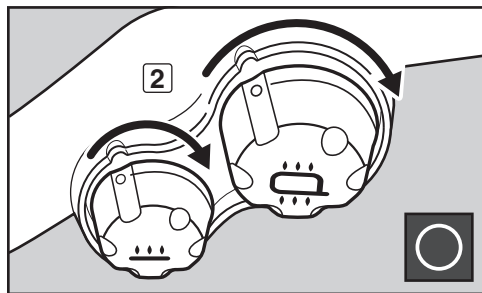
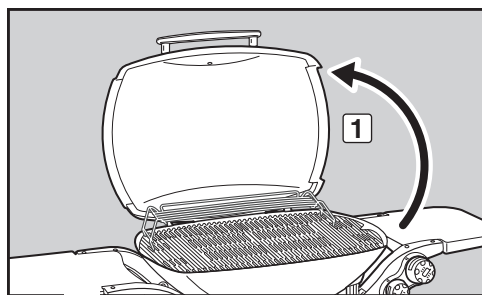

Some batteries have a plastic protective wrap around them. This plastic must be removed before you attempt to ignite your barbecue. Do not confuse this plastic with the battery label.

BURNER IGNITION & USAGE

BURNER IGNITION

Lighting with a Match

A) Open the barbecue lid (1).

⚠ DANGER

Failure to open the lid before igniting the barbecue's burners, or not waiting five minutes to allow the gas to clear if the barbecue does not light, may result in an explosive flare-up which can cause serious bodily injury or death.

- B) Make sure **ALL** burner control knobs are turned off (2). Check by pushing burner control knobs in and turning them clockwise until they stop.
- C) Turn on the cylinder valve using one of the appropriate options based on your cylinder and regulator type.
- D) Strike a match and put the flame under the matchlight hole (3). While holding lit match, light the outside burner by pushing the large burner control knob in and turning it counterclockwise to start/high (⚡) position (4).
- E) Check that the burner is lit by looking through the cooking grates. You should see a flame.

⚠ WARNING: Do not lean over the open barbecue while igniting. Keep your face and body at least 30 cm (12 in) away from the matchlight hole when lighting the barbecue.

⚠ WARNING: If the burner fails to ignite within five seconds, stop, turn the burner control knob to off and wait five minutes to allow the gas to clear before you try again or light with a match.

- F) After the outside burner is lit, you can turn on the inside burner. Push in the small burner control knob and turn it to start/high (⚡) position (5). The inside burner will then be ignited by the outside burner.

TO EXTINGUISH BURNER

Push each burner control knob in and turn it clockwise to the off (○) position. Turn gas supply off at the source.

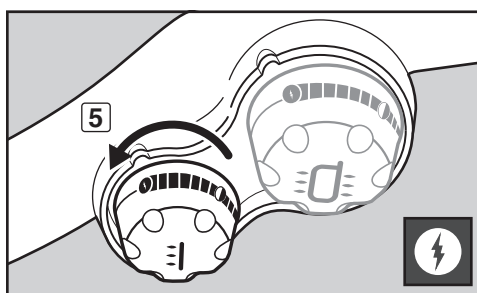
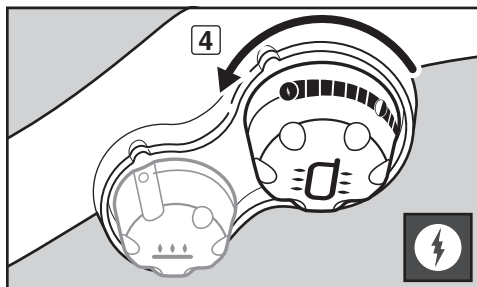
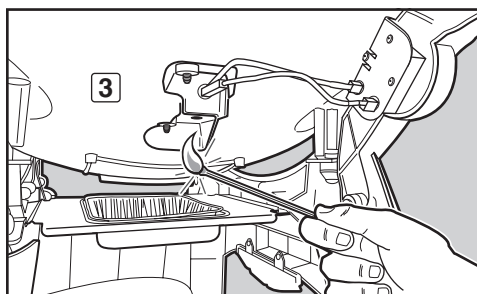
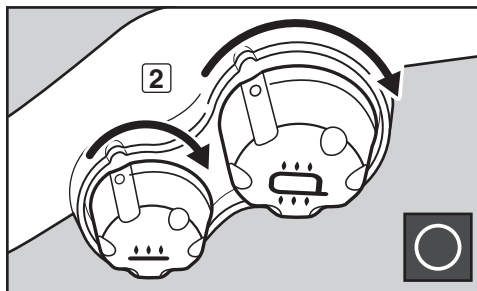
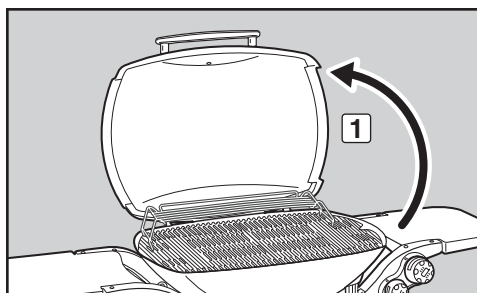

TIPS & HINTS

- Always preheat the barbecue before cooking. Set burner(s) on high heat and close lid; preheat for 10 to 15 minutes.
- The temperature of your gas barbecue may run hotter than normal for the first few uses.
- Recipe barbecuing times are based on outside temperatures of 70°F (21°C) and little or no wind. Allow for more cooking time on cold or windy days, or at higher altitudes. Allow for less cooking time in extremely hot weather.
- Barbecuing conditions may require adjustment of the burner control knobs to attain the correct cooking temperatures.
- Sear meats and cook with the lid down for perfectly barbecued food every time.
- Crowding food onto a cooking grate means more time will be required to cook the food.
- Trim excess fat from steaks, chops, and roasts, leaving no more than a scant ¼ inch (6.4 mm) of fat. Less fat makes clean-up easier, and is a virtual guarantee against unwanted flare-ups.
- In general, large pieces of meat will require more cooking time per pound (kilo) than small pieces of meat.
- Some foods, such as a casserole or thin fish fillets, will require a container for barbecuing. Disposable foil pans are very convenient, but any metal pan with ovenproof handles can also be used.
- Foods in containers, such as baked beans, will require more time if barbecued in a deep casserole than in a shallow baking pan.
- Use tongs rather than a fork for turning and handling meats to avoid losing natural juices. Use two spatulas for handling large whole fish.
- Always be sure the cookbox and removable catch pan are clean and free from debris.
- Do not line the cookbox with foil. This could prevent the grease from flowing into the removable catch pan.
- If an unwanted flare-up should occur, turn burner(s) off and move food to another area of the cooking grate. Any flames will quickly subside. After flames subside, relight the barbecue. **NEVER USE WATER TO EXTINGUISH FLAMES ON A GAS barbecue.**
- Using a timer will help to alert you when “well done” is about to become “overdone.”
- A light coating of oil will help brown your food evenly and keep it from sticking to the cooking grate. Always brush or spray oil onto your food, not directly onto the cooking grate.
- When using a marinade, sauce or glaze with a high sugar content or other ingredients that burn easily, only brush it onto the food during the last 5 to 10 minutes of barbecuing.

PREHEATING

Preheating the barbecue before barbecuing is important. To preheat: Light your barbecue according to the instructions in this Owner's Guide; then turn burner(s) to start/high (†) position, close the lid, and preheat barbecue. This will take 10 to 15 minutes depending on conditions such as air temperature and wind. After preheating, you can adjust the burner(s) as desired.

⚠ WARNING: Should the burner(s) go out while barbecue is in operation, turn burner control knob(s) to off position. Open the lid and wait five minutes before attempting to relight barbecue, using the igniting instructions.

COVERED COOKING

All barbecuing is done with the lid down to provide uniform, evenly circulated heat. With the lid closed, the gas barbecue cooks much like a convection oven. The thermometer in the lid, a feature on some of our barbecues, indicates the cooking temperature inside the barbecue. All preheating and barbecuing is done with the lid down. No peeking — heat is lost every time you lift the lid.

GREASE COLLECTION SYSTEM

Unique cooking grate design features angled, cast-iron rails that deflect drippings away from the burner tube(s), preventing flare-ups that can char food. The remaining drippings flow into a removable catch pan that slides out for easy cleaning.

For more barbecuing tips and recipes, visit www.weber.com®.

BARBECUING TIPS & HELPFUL HINTS

RED MEAT	Thickness / Weight	Approximate Total Barbecuing Time
Steak: New York strip, rib-eye, and filet mignon (tenderloin)	¾ inch thick	3 to 5 minutes direct high heat
	1 inch thick	6 to 8 minutes direct high heat
Steak: Porterhouse and T-bone	¾ inch thick	4 to 6 minutes direct high heat
	1 inch thick	8 to 10 minutes direct high heat
Flank Steak	1½ to 2 pounds, ¾ inch thick	12 to 14 minutes direct high heat
Ground Beef Patty	¾ inch thick	8 to 10 minutes direct medium heat
Tenderloin	3 to 4 pounds	25 to 30 minutes sear 10 minutes direct high heat, and barbecue 15 to 20 minutes indirect low heat
PORK	Thickness / Weight	Approximate Total Barbecuing Time
Bratwurst: fresh	5 ounce link	10 to 15 minutes direct low heat
Chop: boneless or bone in	¾ inch thick	10 to 15 minutes sear 6 minutes direct high heat, and barbecue 4 to 8 minutes indirect low heat
	1¼ to 1½ inches thick	14 to 18 minutes sear 8 minutes direct high heat, and barbecue 6 to 10 minutes indirect low heat
Ribs: baby back	3 to 4 pounds	1 to 1½ hours indirect low heat (with rib rack**)
Ribs: spareribs	3 to 4 pounds	1 to 1½ hours indirect low heat, 30 minutes bone side down, then turn every 10 to 15 minutes
Tenderloin	1 pound	20 to 25 minutes sear 10 minutes direct high heat (turn 3 times), and barbecue 10 to 15 minutes indirect low heat
POULTRY	Thickness / Weight	Approximate Total Barbecuing Time
Chicken Breast: boneless, skinless	6 to 8 ounces	12 to 16 minutes direct medium heat
Chicken Pieces: bone in, assorted	3 to 6 ounces	35 to 45 minutes direct low heat
Chicken: whole	4 to 5 pounds	1 to 1½ hours indirect medium heat (with roasting rack**)
Cornish Game Hen	3 to 4 pounds	30 to 35 minutes indirect medium heat (with roasting rack**)
Turkey Breast: bone in	5 to 6 pounds	1 to 1½ hours indirect low heat
SEAFOOD	Thickness / Weight	Approximate Total Barbecuing Time
Fish, Fillet or Steak: salmon, swordfish, and tuna	¼ to ½ inch thick	6 to 8 minutes direct medium heat
	1 to 1¼ inches thick	8 to 10 minutes direct medium heat
Fish, Fillet or Steak: halibut and sea bass	¼ to ½ inch thick	10 to 12 minutes direct medium heat
	1 to 1¼ inches thick	12 to 14 minutes direct medium heat
Shrimp	1½ ounces	3 to 5 minutes direct medium heat
VEGETABLES	Thickness / Weight	Approximate Total Barbecuing Time
Asparagus	1½ inch diameter	3 to 5 minutes direct medium heat
Corn	in husk	25 to 30 minutes direct medium heat
	husked	10 to 15 minutes direct medium heat
Mushroom	shitake or button	8 to 10 minutes direct medium heat
	portabello	12 to 15 minutes direct medium heat
Onion	½ inch slices	8 to 12 minutes direct medium heat
Potato	whole	45 to 60 minutes indirect low heat
	½ inch slices	14 to 16 minutes direct medium heat







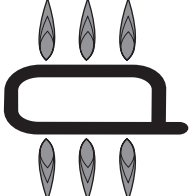

**Sold separately.

COOKING METHODS

DIRECT METHOD OR INDIRECT METHOD?

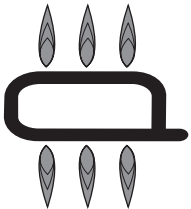
The most important thing to know about barbecuing is which cooking method to use for a specific food, direct or indirect. The difference is simple. With the direct method, which is similar to broiling, the food is cooked directly over the fire. With the indirect method, fire is arranged on either side of the food. The indirect method is similar to roasting, but with the added benefits of that grilled texture, flavour, and appearance you can't get from cooking with an oven. Using the right method is the shortest route to great results—and the best way to ensure safely cooked food.

With each method, you can adjust the burners as desired. The control settings — HIGH, MEDIUM, LOW, or OFF — are described in the chart to the right. For example, to sear steaks, set both burners to HI, then to complete cooking, set both burners to LOW. For great barbecuing inspiration, visit www.weber.com/recipes.

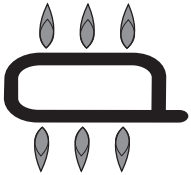
COOKING METHOD AND USES	INSIDE BURNER CONTROL SETTING	OUTSIDE BURNER CONTROL SETTING
PREHEAT	 HIGH	 HIGH
DIRECT LOW Chicken pieces, sausage	 LOW	 LOW
SEARING Steak and items that require searing <i>Start by searing thick steaks over direct high heat...</i> <i>...finish by cooking over direct low heat</i>	 HIGH	 HIGH
	 LOW	 LOW
INDIRECT Small whole chicken	 OFF	 MEDIUM

TROUBLESHOOTING

GENERAL TROUBLESHOOTING

PROBLEMS	SOLUTIONS
Burner does not ignite when you push the igniter button.	<p>Be sure that there is gas flow to the burners by attempting to match light your burner. Refer to “BURNER IGNITION—Lighting with a Match.” If match lighting is successful, the problem lies in the ignition system. Refer to “MAINTAINING THE PUSH BUTTON IGNITION SYSTEM (Q® 3000)” or “MAINTAINING THE ELECTRONIC IGNITION SYSTEM (Q® 3200).”</p> <p>Be sure that wires are correctly inserted into terminals on igniter electrode assembly. Check that the wires are connected to terminals on the push button igniter (Q® 3000) or the electronic igniter module (Q® 3200). Refer to “MAINTAINING THE PUSH BUTTON IGNITION SYSTEM (Q® 3000)” or “MAINTAINING THE ELECTRONIC IGNITION SYSTEM (Q® 3200).”</p> <p>If a new battery is installed, confirm that battery’s plastic wrapping has been removed. Verify that the battery is in good condition and has been installed correctly. Refer to “MAINTAINING THE ELECTRONIC IGNITION SYSTEM (Q® 3200).”</p>
<p>Burners do not ignite.</p> <p>Burners have a small flickering flame when burner control knobs are on the high (†) position.</p> <p>Barbecue temperature only reaches 250° to 300° F (121° to 149° C) when burner control knobs are on the high (†) position.</p>	<p><i>Some countries have regulators with an excess gas flow safety device.</i> The excess gas flow safety device, which is part of the barbecue-to-cylinder connection, may have been activated. To reset the excess gas flow safety device, close the cylinder valve and turn all burner control knobs to the off (○) position. Open the barbecue lid. Wait at least five minutes for the gas to clear before attempting to light the barbecue. SLOWLY turn the cylinder valve until it is completely open. Wait several seconds; then ignite your barbecue. Refer to “MAIN BURNER IGNITION & USAGE.”</p>
Burner does not ignite, or flame is low when burner control knob is on high (†) position.	<p>Fuel could be low or empty. Refill cylinder.</p> <p>Fuel hose could be bent or kinked. Straighten fuel hose.</p>
<p>Burner flame pattern is erratic.</p> <p>Flame is low when burner control knob is on high (†) position.</p> <p>Flames do not run the whole length of the burner tube.</p>	<p>Clean burner ports that run down the entire length of burner tube. Refer to “ANNUAL MAINTENANCE.”</p>
Burners burn with a yellow or orange flame, in conjunction with the smell of gas.	<p>Inspect spider/insect screens for possible obstructions. (Blockage of holes.) Clean spider/insect screens. Refer to “ANNUAL MAINTENANCE.”</p>
Experiencing flare-ups.	<p>Barbecue must be preheated with all burners on high for 10 to 15 minutes.</p>
⚠ CAUTION: Do not line the cookbox with aluminium foil.	<p>Clean the cooking grates thoroughly to remove grease. Refer to “CLEANING THE INSIDE OF THE BARBECUE.”</p> <p>The cookbox may be dirty and is not allowing grease to flow into removable catch pan. Clean cookbox. Refer to “CLEANING THE INSIDE OF THE BARBECUE.”</p>
Inside of lid appears to be “peeling.” (Resembles paint peeling.)	<p>The inside of the lid is cast aluminium. It is not painted. It cannot “peel.” What you are seeing is baked-on grease that has turned to carbon and is flaking off. THIS IS NOT A DEFECT. Clean thoroughly. Refer to “CLEANING THE INSIDE OF THE BARBECUE.”</p>

If problems cannot be corrected by using these methods, please contact the Customer Service Representative in your area using the contact information on our web site. Log onto www.weber.com®.

GRILL OUT® HANDLE LIGHT TROUBLESHOOTING

PROBLEMS	SOLUTIONS
Grill Out® Handle Light does not light.	<p>If a new battery is installed, confirm that battery’s plastic wrapping has been removed. Verify that the battery is in good condition and has been installed correctly. Refer to “MAINTAINING THE GRILL OUT® HANDLE LIGHT.”</p> <p>Light will activate only when lid is open and power button is ON. Lift lid to up position and push power button on.</p>

If problems cannot be corrected by using these methods, please contact the Customer Service Representative in your area using the contact information on our web site. Log onto www.weber.com®.

KEEPING YOUR WEBER® GAS BARBECUE IN TIP-TOP SHAPE

⚠ DANGER

Failure to correct any problems described on this page may result in a fire, which can cause serious bodily injury or death, and cause damage to property.

To keep your Weber® gas barbecue performing as safely and efficiently as on day one, we strongly recommend that you inspect and clean the spider/insect screen(s) and burner tube(s) at least once a year. Below is important information about these two areas of the barbecue that should undergo annual maintenance.

If you observe an incorrect flame pattern or blocked burner port, proceed to the “BURNER TUBE CLEANING OR REPLACEMENT” instructions on the following page.

BURNER FLAME PATTERN

The burner tube(s) in your Weber® gas barbecue was/were factory set for the correct air and gas mixture. The correct flame pattern is shown in illustration and described below:

- Burner tube(s) (1)
- Tips occasionally flicker yellow (2)
- Light blue (3)
- Dark blue (4)

Check burner flame pattern. If the flames do not match the above description, it could be an indication that the spider/insect screen(s) has/have become dirty or blocked.

WEBER® SPIDER/INSECT SCREEN(S)

The combustion air opening(s) of the burner tube(s) (5) is/are fitted with stainless steel screen(s) to help prevent spiders and other insects from spinning webs and building nests inside the venturi section (6) of the burner tube(s). These nests can obstruct the normal gas flow, and can cause gas to flow back out of the combustion air opening(s) (7). Symptoms of this kind of obstruction include the odour of gas in conjunction with burner flames that appear yellow and lazy. This obstruction could result in a fire in and around the gas valve(s), causing serious damage to your barbecue (8).

NOTE: If a spider/insect screen becomes damaged or cannot be cleaned, please contact the Customer Service Representative in your area using the contact information on our web site. Log onto www.weber.com.

BURNER TUBE PORTS

Over time, from repeated use of the barbecue, the burner tube ports will become dirty. Blocked and dirty ports can restrict full gas flow. Following are ways to determine whether burner tube ports are dirty or blocked.

- Barbecue does not reach desired temperature
- Barbecue heats unevenly
- One or more of the burner(s) do not ignite

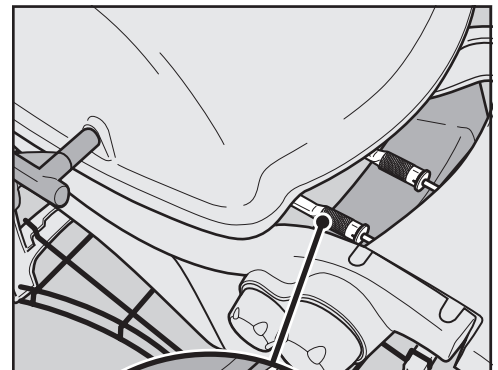
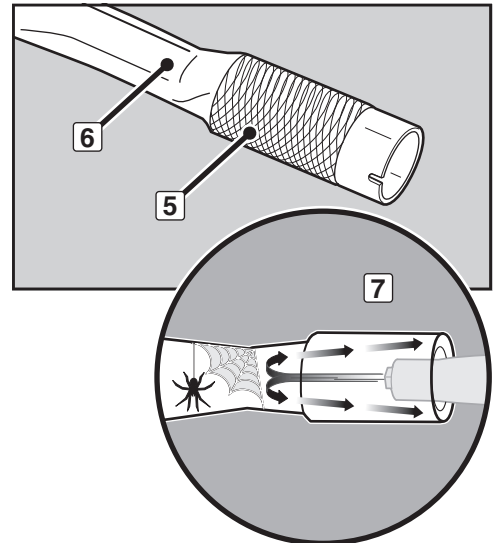
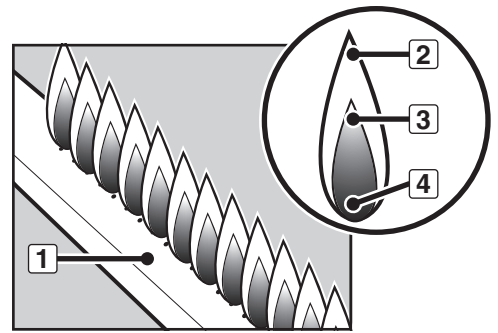

ANNUAL MAINTENANCE

BURNER TUBE CLEANING OR REPLACEMENT

Confirm that Barbecue is Off and Cool

- Turn gas supply off at source and disconnect LPG cylinder.
- Check that all burner control knobs are in the off (O) position. Check by pushing burner control knobs in and turning them clockwise until they stop. If they do not turn, they are already off. If they do turn, continue turning them clockwise until they stop; then they are off.
- Open lid and remove cookbox components.

Remove Burner Tubes

You will need: A 3/8" spanner.

- Remove the screw that holds the outside burner tube to the cookbox (1).
 - Rotate the outside burner tube 90°. Slide and lift burner tube away from valve orifice and remove from cookbox (2).
 - Repeat this procedure for the inside burner tube (3).
- ⚠ CAUTION: Care must be taken when removing or reinstalling burner tubes. Do not force or bend the gas lines that connect the control valves to the burner tubes (4).**

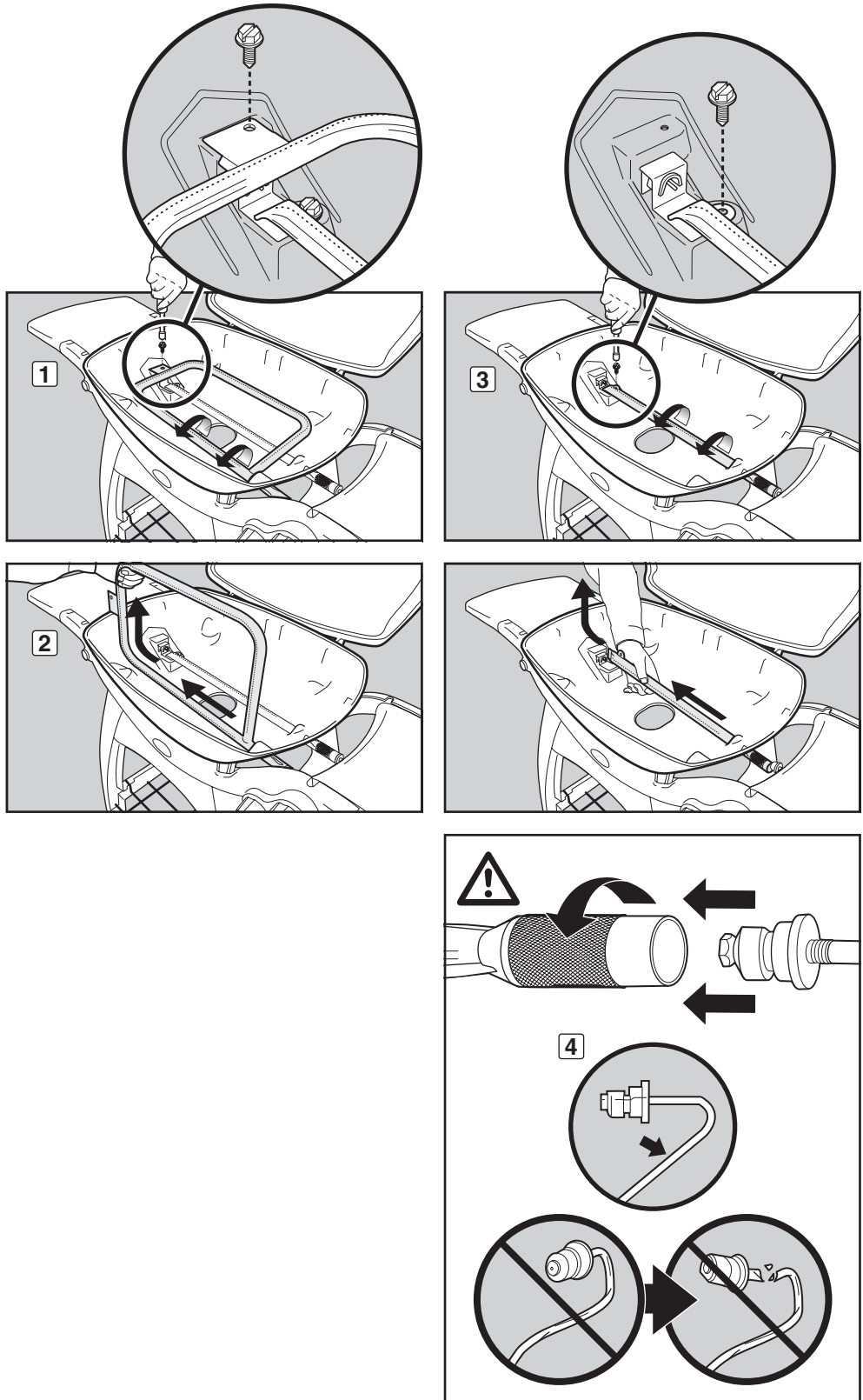

ANNUAL MAINTENANCE

Clean Burner Tubes

You will need: A torch, a wire (a straightened-out coat hanger), a suitable stainless steel bristle brush, and a soft bristle brush (toothbrush).

- A) Look inside each burner tube with a torch (5).
- B) Clean any debris or blockage from the inside of the burner tubes with the wire (6).
- C) Check spider/insect screens at the ends of the burner tubes and clean them using the soft bristle brush (7).

⚠ CAUTION: Do not clean the spider/insect screens with hard or sharp tools. Do not dislodge the spider/insect screens or enlarge the screen openings.

- D) Use the steel bristle brush to clean the outside of the burner tubes. This is done to make sure all burner ports (openings) running along the length of the burner tubes are fully open.

⚠ CAUTION: Do not enlarge the burner ports when cleaning.

Reinstall Burner Tubes

You will need: A 3/8" spanner.

- A) Carefully slide the inside burner tube back into hole in right side of cookbox (9), aligning burner tube opening with valve orifice (10).
- B) Reinstall screw that holds the inside burner tube to the cookbox.
- C) Repeat this procedure for the outside burner tube (11).

⚠ CAUTION: The burner tube openings (12) must be positioned properly over the valve orifices (13).

⚠ WARNING: You should check for gas leaks every time you disconnect and reconnect a gas fitting. Refer to "CHECKING FOR GAS LEAKS."

- D) Replace cookbox components.

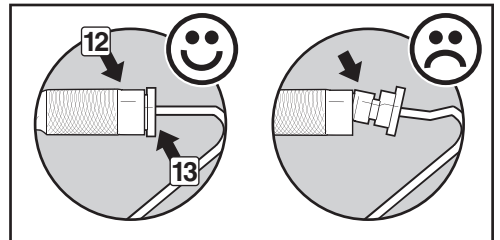
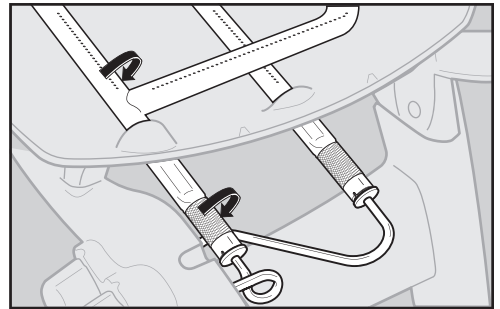
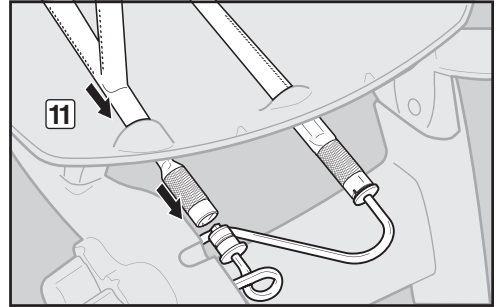
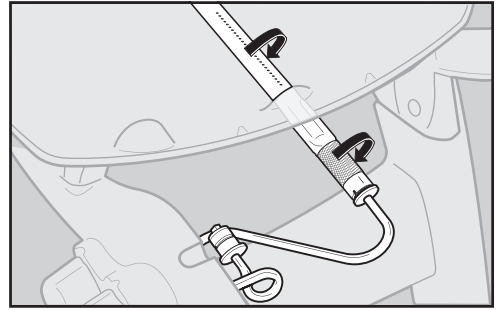
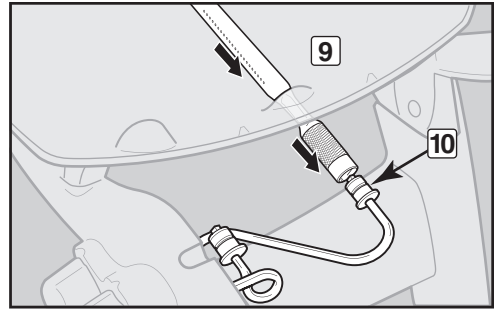
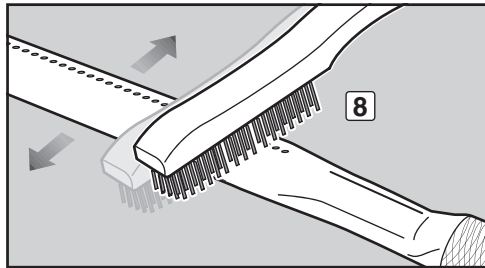
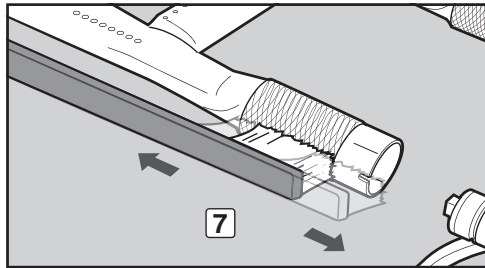
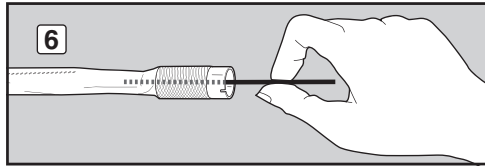
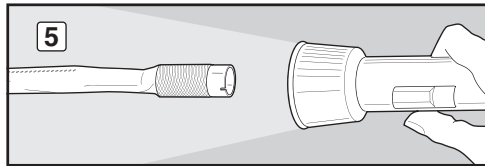

BEAUTIFUL— INSIDE AND OUT

Weber® barbecue owners take a lot of pride in their barbecues. Flaunt your pride and joy. Keep your barbecue clean and beautiful—inside and out—by following these routine maintenance steps.

CLEANING THE OUTSIDE OF THE BARBECUE

To keep the outside of your barbecue looking its best, use the following guidelines for safe cleaning.

⚠ WARNING: Turn your Weber® gas barbecue off and wait for it to cool before cleaning it.

Painted, Enamelled and Plastic Surfaces

Use a warm, soapy water solution to clean outside surfaces; then rinse with water.

IMPORTANT: Do not use cleaners that contain acid, mineral spirits, or xylene. Do not use oven cleaner, abrasive cleansers (kitchen cleansers), cleaners that contain citrus products, or abrasive cleaning pads on barbecue or cart surfaces.

Fold-down tables are not to be used as cutting boards.

CLEANING THE INSIDE OF THE BARBECUE

To keep your barbecue performing safely and efficiently, it is important to remove any debris and excess grease that may have accumulated on the inside of the barbecue. Use the following guidelines for safe cleaning.

Inside Lid

Flaking, built-up grease resembles paint flakes. Wipe inside of lid with paper towel to prevent grease build-up. Wash inside lid with warm, soapy water; then rinse with water.

Cookbox Components & Burner Tubes

You will need: A stainless steel bristle brush, and a stiff plastic scraper.

A) Scrape and brush the cooking grates with the scraper and brush. Remove the cooking grates and set aside.

⚠ CAUTION: Grill brushes should be checked for loose bristles and excessive wear on a regular basis. Replace brush if any loose bristles are found on cooking grates or brush. Weber recommends purchasing a new stainless steel grill brush at the beginning of every spring.

⚠ CAUTION: Do not clean cooking grates in a self-cleaning oven.

B) Brush any debris off of burner tubes. Do not enlarge burner ports (openings) running along length of burner tube (1).

C) When cleaning is complete, replace the cooking grates.

Cookbox

Wash inside of cookbox with warm, soapy water; then rinse with water.

Removable Catch Pan and Disposable Drip Pan

Your barbecue was built with a grease collection system, which funnels grease away from food and into a removable catch pan. For your convenience, you can also line the removable catch pan with a Weber® disposable drip pan, which will help keep the removable catch pan cleaner longer.

Cleaning the removable catch pan is just as important as cleaning the cookbox. Check the removable catch pan for grease build-up each time you use your barbecue. Remove excess grease with a plastic scraper (2). Wash the removable catch pan with warm, soapy water and rinse with water.

⚠ WARNING: Check the removable catch pan or disposable drip pan for grease build-up before each use. Remove excess grease to avoid a grease fire. A grease fire can cause serious bodily injury or damage to property.

⚠ CAUTION: Do not line the cookbox, removable catch pan or disposable drip pan with aluminium foil.

HOSE INSPECTION

The hose should be inspected routinely for any signs of cracking (3).

⚠ WARNING: Check hose before each use of barbecue for nicks, cracking, abrasions or cuts. If the hose is found to be damaged in any way, do not use the barbecue. Replace using only Weber® authorised replacement hose. Contact the Customer Service Representative in your area using the contact information on our web site. Log onto www.weber.com®.

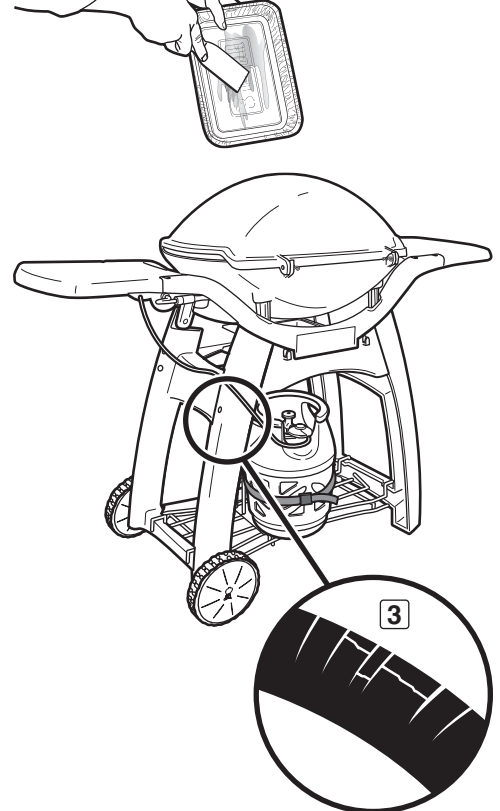
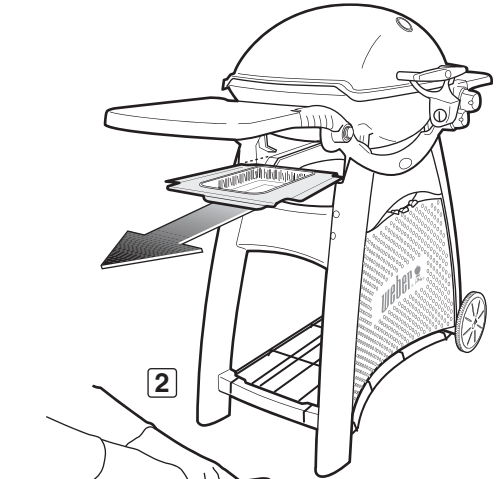
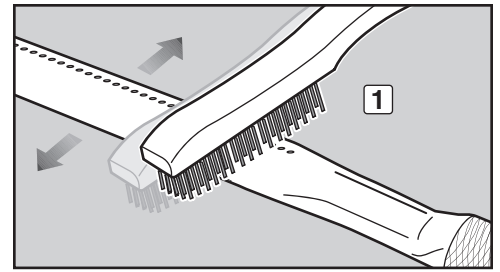

To obtain replacement disposable drip pans and cooking grates, contact the local retailer in your area or log onto www.weber.com®. If you need further assistance, contact your Customer Service Representative.

IGNITION SYSTEM OPERATIONS

The igniter supplies a spark to the igniter electrode assembly. Whether you are performing routine maintenance or a troubleshooting check on the ignition system, read the following to keep your ignition system working properly.

⚠ WARNING: All gas controls and supply valves should be in the OFF position.

If the igniter fails to ignite your Q® barbecue, you will need to pinpoint where the problem is occurring: with the gas flow or with the ignition system. Begin by attempting to match light your burner. Refer to "BURNER IGNITION—Lighting with a Match." If match lighting is successful, the problem lies in the ignition system.

MAINTAINING THE PUSH BUTTON IGNITION SYSTEM (Q® 3000)

- Check that both the white (1) and black (2) ignition wires are attached properly.
- Verify that the igniter button pushes in, clicks and returns to the out position.

MAINTAINING THE ELECTRONIC IGNITION SYSTEM (Q® 3200)

- Verify that the AAA battery (alkaline only) is in good condition and is installed correctly (3). Some batteries have a plastic protective wrap around them. This plastic must be removed before installing battery. Do not confuse this plastic with the battery label.
- Make sure that both igniter wires are properly attached to the igniter module. Black wire to black terminal (4), white wire to white terminal (5).
- Make sure the electronic igniter button is working by listening for clicking and looking for sparks at burner.

If the electronic ignition system still fails to ignite, contact the Customer Service Representative in your area using the contact information on our web site. Log onto www.weber.com®.

MAINTAINING THE GRILL OUT® HANDLE LIGHT (Q® 3200)

- Verify that the three AAA batteries (alkaline only) are in good condition and are installed correctly. Refer to "ASSEMBLY"
- Some batteries have a plastic protective wrap around them. This plastic must be removed before installing battery. Do not confuse this plastic with the battery label.

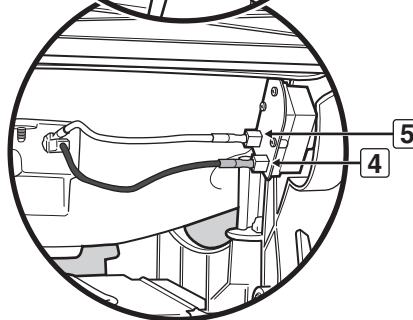
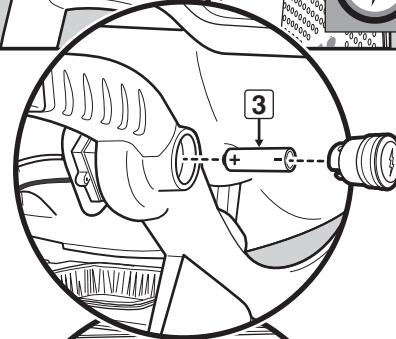
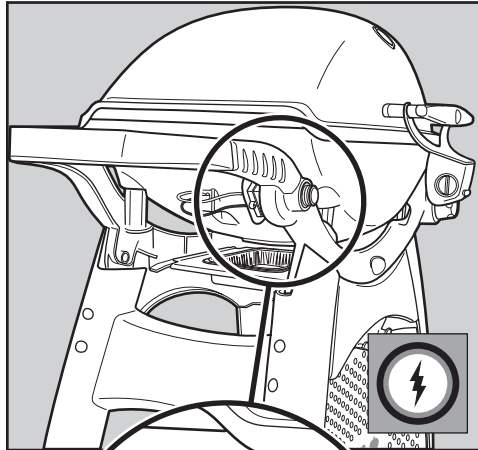
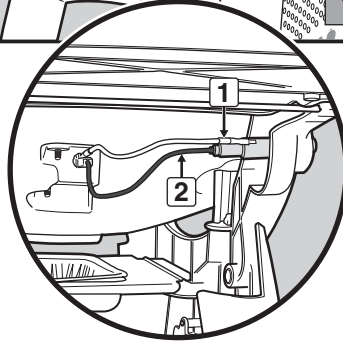
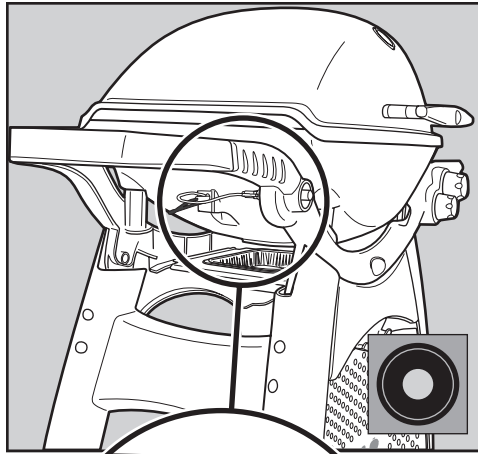

⚠ ATTENTION: This product has been safety-tested and is only certified for use in a specific country. Refer to country designation located on outside of box.

These parts may be gas-carrying or gas-burning components. Please contact Weber-Stephen Products LLC Customer Service Department for genuine Weber-Stephen Products LLC replacement part(s) information.

⚠ WARNING: Do not attempt to make any repair to gas-carrying or gas-burning components without contacting Weber-Stephen Products LLC Customer Service Department. Your actions, if you fail to follow this product warning, may cause a fire or an explosion resulting in serious personal injury or death and damage to property.



This symbol indicates that the product cannot be disposed of with household refuse. For instructions regarding proper disposal of this product in Europe, please visit www.weber.com[®], and contact the importer listed for your country. If you do not have internet access, contact your dealer for the importer's name, address and telephone number.

When you decide to dispose of or discard your grill, all electrical components (e.g., rotisserie motor, batteries, ignition module, handle lights) must be removed and disposed of properly according to WEEE. They should be disposed of separately from the grill.

WEBER-STEPHEN ÖSTERREICH GmbH

Maria-Theresia-Straße 51
4600 Wels
AUSTRIA
TEL: +43 7242 890 135 0; info-at@weberstephen.com

WEBER-STEPHEN PRODUCTS BELGIUM Sprl

Blarenberglaan 6 Bus 4
Industriezone Noord
BE-2800 Mechelen
BELGIUM
TEL: +32 015 28 30 90; infobelux@weberstephen.com

WEBER-STEPHEN CZ & SK spol. s r.o.

U Hajovny 246
25243 Průhonice
CZECH REPUBLIC
TEL: +42 267 312 973; info-cz@weberstephen.com

WEBER-STEPHEN NORDIC ApS

Bøgildsmindevej 23, DK-9400 Nørresundby
DANMARK
TEL: +45 99 36 30 10; info@weberstephen.dk

WEBER-STEPHEN NORDIC MIDDLE EAST

Ras Al Khaimah FTZ
P.O. Box 10559
UNITED ARAB EMIRATES
TEL: +971 4 360 9256; info@weberstephen.ae

WEBER-STEPHEN FRANCE SAS

Eragny sur Oise – C.S. 80322
95617 Cergy Pontoise Cedex
FRANCE
TÉL: +33 810 19 32 37
service.consommateurs@weberstephen.com

WEBER-STEPHEN DEUTSCHLAND GmbH

Rheinstraße 194
55218 Ingelheim
DEUTSCHLAND
TEL: +49 6132 8999 0; info-de@weberstephen.com

WEBER-STEPHEN NETHERLANDS B.V.

Tsjükemarwei 12
8521 NA Sint Nicolaasga
Postbus 18
8520 AA Sint Nicolaasga
NETHERLANDS
TEL: +31 513 4333 22; info@weberbarbecues.nl

JARN & GLER WHOLESAL EHF

Skutuvogur 1H
1-104 Reykjavik
ICELAND
TEL: +354 58 58 900

D&S IMPORTS

14 Shenkar Street
Petach, Tikva 49001
ISRAEL
TEL: +972 392 41119; info@weber.co.il

WEBER-STEPHEN PRODUCTS ITALIA Srl

Centro Polifunzionale "Il Pioppo"
Viale della Repubblica 46
36030 Povolara di Dueville – Vicenza
ITALY
TEL: +39 0444 360 590; info-italia@weberstephen.com

WEBER-STEPHEN POLSKA Sp. z o.o.

Ul. Trakt Lubelski 153
04-766 Warszawa
POLSKA
TEL: +48 22 392 04 69; info-pl@weberstephen.com

GALACTEX OUTDOOR (PTY) LTD.

141-142 Hertz Draai
Meadowdale, Edenvale
Gauteng
SOUTH AFRICA
TEL: +27 11 454 2369; info@weber.co.za

WEBER-STEPHEN IBERICA Srl

Avda. de les Corts Catalanes 9-11 -
Despacho 10 B
E-08173 Sant Cugat del Vallès
Barcelona
SPAIN
TEL: +34 93 584 40 55; infoiberica@weberstephen.com

WEBER-STEPHEN SCHWEIZ GmbH

Talackerstr. 89a
8404 Winterthur
SWITZERLAND
TEL: +41 52 24402 50; info-ch@weberstephen.com

WEBER-STEPHEN PRODUCTS

(U.K.) LIMITED

The Four Columns,
Broughton Hall Business Park
Skipton, North Yorkshire BD23 3AE
UNITED KINGDOM
TEL: +44 01756 692611;
customerservicenwe@weberstephen.com

WEBER-STEPHEN PRODUCTS LLC

200 East Daniels Road
Palatine, IL 60067-6266
USA
TEL: 847 934 5700; support@weberstephen.com

OOO WEBER-STEPHEN Vostok

142784 Moscow Region,
Leninskiy District
Rumyantsevo Village
Building 1
RUSSIA
TEL: +7 495 973 16 49; info.ru@weberstephen.com

WEBER-STEPHEN MAGYARORSZÁG KFT.

1138 Budapest, Váci út 186.
HUNGARY
TEL: +36 70 / 70-89-813; info-hu@weberstephen.com

For Republic of Ireland, please contact:
Weber-Stephen Products (U.K.) Limited.

For other eastern European countries,
such as ROMANIA, SLOVENIA, CROATIA,
TURKEY, or GREECE, please contact:
Weber-Stephen Deutschland GmbH,
info-EE@weberstephen.com.

For Baltic states, please contact:
Weber-Stephen Nordic ApS.



WEBER-STEPHEN PRODUCTS LLC

www.weber.com[®]

© 2013 Designed and engineered by Weber-Stephen Products LLC,
200 East Daniels Road, Palatine, Illinois 60067 U.S.A.
Printed in U.S.A.

The Weber[®] Q[®] grill includes designs and features originally created by Robert DeMars of Original Ideas, Inc.

The Q[®] Cart[®] includes designs and features originally created by Robert DeMars of Original Ideas, Inc.